

**MODERN
NETWORKING**

Index

Programme Specific Outcome	Simulating Routing –Switching Techniques
Practical No	Details
1	Configure IP SLA Tracking and Path Control Topology
2	Using the AS_PATH Attribute
3	Configuring IBGP and EBGP Sessions, Local Preference, and MED
4	Secure the Management Plane
5	Configure and Verify Path Control Using PBR
6	IP Service Level Agreements and Remote SPAN in a Campus Environment
7	Inter-VLAN Routing
8	Simulating MPLS environment
9	Simulating VRF

Practical 1

NETWORK TOPOLOGY

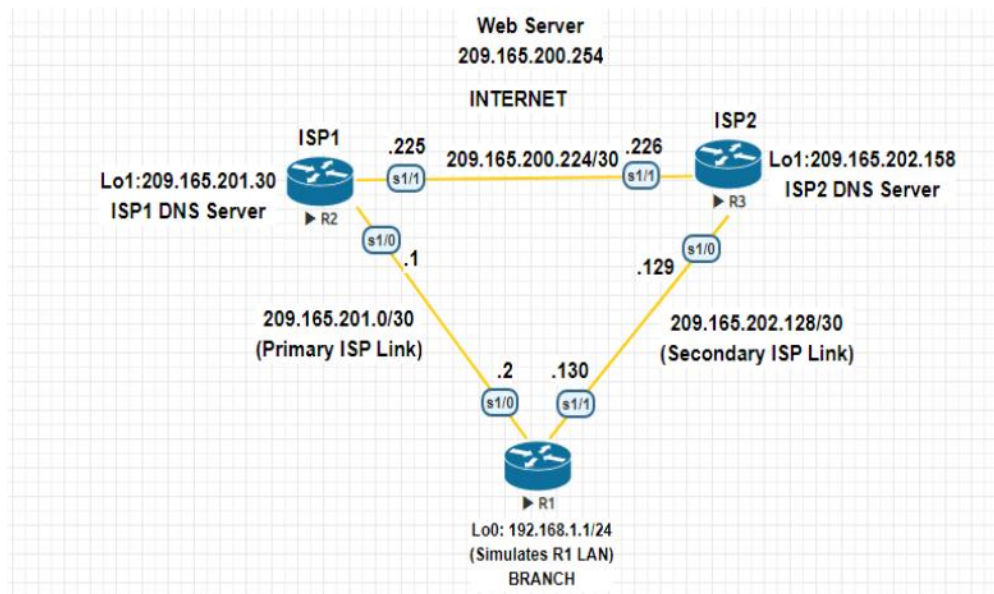

R1

```
Router>enable
```

```
Router# conf t R
```

```
outer(config)#hostname R1
```

```
R1(config)#interface Loopback 0
```

```
R1(config-if)#ip address 192.168.1.1 255.255.255.0
```

```
R1(config-if)#exit
```

```
R1(config)#interface s1/0
```

```
R1(config-if)#ip address 209.165.201.2 255.255.255.252
```

```
R1(config-if)#no shutdown
```

```
R1(config-if)#exit
```

```
R1(config)#interface s1/1
```

```
R1(config-if)#ip address 209.165.202.130 255.255.255.252
```

```
R1(config-if)#no shutdown
```

```
R1(config-if)#exit
```

```
R1(config)#ip route 0.0.0.0 0.0.0.0 209.165.201.1
```

```
R1(config)#ip sla 12
```

```
R1(config-ip-sla)#icmp-echo 209.165.201.30
```

```
R1(config-ip-sla-echo)#frequency 11
```

```
R1(config-ip-sla-echo)#exit
```

```
R1(config)#ip sla schedule 12 life forever start-time now R
```

```
1#sh ip sla configuration 12
```

```
IP SLAs Infrastructure Engine-III
```

```
Entry number: 12
```

```
Owner:
```

```
Tag:
```

```
Operation timeout (milliseconds): 5000
```

```
Type of operation to perform: icmp-echo
```

```
Target address/Source address: 209.165.201.30/0.0.0.0
```

Type Of Service parameter: 0x0
Request size (ARR data portion): 28
Verify data: No
Vrf Name:
Schedule:
Operation frequency (seconds): 11 (not considered if randomly scheduled)
Next Scheduled Start Time:
e: Start Time already passed
Group Scheduled : FALSE Randomly Scheduled : FALSE
Life (seconds): Forever
Entry Ageout (seconds): never
Recurring (Starting Everyday): FALSE
Status of entry (SNMP RowStatus): Active
Threshold (milliseconds): 5000
Distribution Statistics:
Number of statistic hours kept: 2
Number of statistic distribution buckets kept: 1
Statistic distribution interval (milliseconds): 20
Enhanced History:
History Statistics:
Number of history Lives kept: 0
Number of history Buckets kept: 15
History Filter Type: None R1#sh ip sla statistics
IPSLAs Latest Operation Statistics
IPSLA operation id: 12
Latest RTT: 11 milliseconds
Latest operation start time: 18:21:25 EET Thu Apr 9 2020
Latest operation return code: OK
Number of successes: 22
Number of failures: 0
Operation time to live: Forever
R1(config)#ip sla 24
R1(config-ip-sla)#icmp-echo 209.165.202.158
R1(config-ip-sla-echo)#frequency 10
R1(config-ip-sla-echo)#exit
R1(config)#ip sla schedule 24 life forever start-time now
R1#sh ip sla configuration 24
IP SLAs Infrastructure Engine-III
Entry number: 24
Owner:
Tag:
Operation timeout (milliseconds): 5000
Type of operation to perform: icmp-echo
Target address/Source address: 209.165.202.158/0.0.0.0
Type Of Service parameter: 0x0
Request size (ARR data portion): 28

Verify data: No Vrf Name:

Schedule:

Operation frequency (seconds): 10 (not considered if randomly scheduled)

Next Scheduled Start Time: Start Time already passed

Group Scheduled : FALSE

Randomly Scheduled : FALSE

Life (seconds): Forever

Entry Ageout (seconds): never

Recurring (Starting Everyday): FALSE

Status of entry (SNMP RowStatus): Active

Threshold (milliseconds): 5000

Distribution Statistics:

Number of statistic hours kept: 2

Number of statistic distribution buckets kept: 1

Statistic distribution interval (milliseconds): 20

Enhanced History:

History Statistics:

Number of history Lives kept: 0

Number of history Buckets kept: 15

History Filter Type: None

R1#sh ip sla statistics 24

IPSLAs Latest Operation Statistics

IPSLA operation id: 24 Latest RTT: 20 milliseconds

Latest operation start time: 18:33:25 EET Thu Apr 9 2020

Latest operation return code: OK

Number of successes: 16

Number of failures: 0

Operation time to live: Forever

R1(config)#no ip route 0.0.0.0 0.0.0.0 209.165.201.1

R1(config)#ip route 0.0.0.0 0.0.0.0 209.165.201.1 5

R1#sh ip route

Codes: L - local, C - connected, S - static, R - RIP, M - mobile, B - BGP D - EIGRP, EX - EIGRP external, O - OSPF, IA - OSPF inter area N1 - OSPF NSSA external type 1, N2 - OSPF NSSA external type 2 E1 - OSPF external type 1, E2 - OSPF external type 2 i - IS-IS, su - IS-IS summary, L1 - IS-IS level-1, L2 - IS-IS level-2 ia - IS-IS inter area, * - candidate default, U - per-user static route o - ODR, P - periodic downloaded static route, H - NHRP, I - LISP a - application route + - replicated route, % - next hop override

Gateway of last resort is 209.165.201.1 to network 0.0.0.0

S* 0.0.0.0/0 [5/0] via 209.165.201.1 192.168.1.0/24 is variably subnetted, 2 subnets, 2 masks

C 192.168.1.0/24 is directly connected, Loopback0

L 192.168.1.1/32 is directly connected, Loopback0 209.165.201.0/24 is variably subnetted, 2 subnets, 2 masks

C 209.165.201.0/30 is directly connected, Serial1/0

L 209.165.201.2/32 is directly connected, Serial1/0 209.165.202.0/24 is variably subnetted, 2 subnets, 2 masks

C 209.165.202.128/30 is directly connected, Serial1/1

```

L 209.165.202.130/32 is directly connected, Serial1/1
R1(config)#track 1 ip sla 12 reachability
R1(config-track)#delay down 10 up 1
R1(config-track)#exit
R1(config)#ip route 0.0.0.0 0.0.0.0 209.165.201.1 2 track 1
R1(config)#track 2 ip sla 12 reachability
R1(config-track)#delay down 10 up 1
R1(config-track)#exit
R1(config)#ip route 0.0.0.0 0.0.0.0 209.165.201.1 3 track 2
R1#sh ip route
Codes: L - local, C - connected, S - static, R - RIP, M - mobile, B - BGP D - EIGRP, EX - EIGRP
external, O - OSPF, IA - OSPF inter area N1 - OSPF NSSA external type 1, N2 - OSPF NSSA
external type 2 E1 - OSPF external type 1, E2 - OSPF external type 2 i - IS-IS, su - IS-IS
summary, L1 - IS-IS level-1, L2 - IS-IS level-2 ia - IS-IS inter area, * - candidate default, U - per-
user static route o - ODR, P - periodic downloaded static route, H - NHRP, I - LISP a -
application route + - replicated route, % - next hop override
Gateway of last resort is 209.165.201.1 to network 0.0.0.0
S* 0.0.0.0/0 [3/0] via 209.165.201.1 192.168.1.0/24 is variably subnetted, 2 subnets, 2
masks
C 192.168.1.0/24 is directly connected, Loopback0
L 192.168.1.1/32 is directly connected, Loopback0 209.165.201.0/24 is variably subnetted, 2
subnets, 2 masks
C 209.165.201.0/30 is directly connected, Serial1/0
L 209.165.201.2/32 is directly connected, Serial1/0 209.165.202.0/24 is variably subnetted,
2 subnets, 2 masks
C 209.165.202.128/30 is directly connected, Serial1/1
L 209.165.202.130/32 is directly connected, Serial1/1
R1#sh ip route
Codes: L - local, C - connected, S - static, R - RIP, M - mobile, B - BGP D - EIGRP, EX - EIGRP
external, O - OSPF, IA - OSPF inter area N1 - OSPF NSSA external type 1, N2 - OSPF NSSA
external type 2 E1 - OSPF external type 1, E2 - OSPF external type 2 i - IS-IS, su - IS-IS
summary, L1 - IS-IS level-1, L2 - IS-IS level-2 ia - IS-IS inter area, * - candidate default, U - per-
user static route o - ODR, P - periodic downloaded static route, H - NHRP, I - LISP a -
application route + - replicated route, % - next hop override
Gateway of last resort is 209.165.201.1 to network 0.0.0.0
S* 0.0.0.0/0 [5/0] via 209.165.201.1 192.168.1.0/24 is variably subnetted, 2 subnets, 2
masks
C 192.168.1.0/24 is directly connected, Loopback0
L 192.168.1.1/32 is directly connected, Loopback0 209.165.201.0/24 is variably subnetted,
2 subnets, 2 masks
C 209.165.201.0/30 is directly connected, Serial1/0
L 209.165.201.2/32 is directly connected, Serial1/0 209.165.202.0/24 is variably subnetted,
2 subnets, 2 masks
C 209.165.202.128/30 is directly connected, Serial1/1
L 209.165.202.130/32 is directly connected, Serial1/1
R1#sh ip sla statistics
IPSLAs Latest Operation Statistics

```

IPSLA operation id: 12
Latest RTT: NoConnection/Busy/Timeout
Latest operation start time: 19:02:29 EET Thu Apr 9 2020
Latest operation return code: Timeout
Number of successes: 227
Number of failures: 19
Operation time to live: Forever

IPSLA operation id: 24
Latest RTT: 20 milliseconds
Latest operation start time: 19:02:35 EET Thu Apr 9 2020
Latest operation return code: OK
Number of successes: 190
Number of failures: 1
Operation time to live: Forever

R1#trace 209.165.200.254 source 192.168.1.1

Type escape sequence to abort.

Tracing the route to 209.165.200.254

VRF info: (vrf in name/id, vrf out name/id)

1 209.165.201.1 10 msec 14 msec *

R1#sh ip sla statistics

IPSLAs Latest Operation Statistics

IPSLA operation id: 12

Latest RTT: 10 milliseconds

Latest operation start time: 19:07:04 EET Thu Apr 9 2020

Latest operation return code: OK

Number of successes: 236

Number of failures: 35

Operation time to live: Forever

IPSLA operation id: 24 Latest RTT: 21 milliseconds

Latest operation start time: 19:07:05 EET Thu Apr 9 2020

Latest operation return code: OK

Number of successes: 217

Number of failures: 1

Operation time to live: Forever

R1#sh ip route

Codes: L - local, C - connected, S - static, R - RIP, M - mobile, B - BGP D - EIGRP, EX - EIGRP external, O - OSPF, IA - OSPF inter area N1 - OSPF NSSA external type 1, N2 - OSPF NSSA external type 2 E1 - OSPF external type 1, E2 - OSPF external type 2 i - IS-IS, su - IS-IS summary, L1 - IS-IS level-1, L2 - IS-IS level-2 ia - IS-IS inter area, * - candidate default, U - per-user static route o - ODR, P - periodic downloaded static route, H - NHRP, I - LISP a - application route + - replicated route, % - next hop override

Gateway of last resort is 209.165.201.1 to network 0.0.0.0

S* 0.0.0.0/0 [3/0] via 209.165.201.1 192.168.1.0/24 is variably subnetted, 2 subnets, 2 masks

C 192.168.1.0/24 is directly connected, Loopback0

L 192.168.1.1/32 is directly connected, Loopback0 209.165.201.0/24 is variably subnetted, 2 subnets, 2 masks

```
C 209.165.201.0/30 is directly connected, Serial1/0
L 209.165.201.2/32 is directly connected, Serial1/0 209.165.202.0/24 is variably subnetted,
2 subnets, 2 masks
C 209.165.202.128/30 is directly connected, Serial1/1
L 209.165.202.130/32 is directly connected, Serial1/1
ISP1 (R2)
Router>enable
Router#conf t
Router(config)#hostname ISP1
ISP1(config)#interface Loopback0
ISP1(config-if)#description Simulated Internet Web Server
ISP1(config-if)#ip address 209.165.200.254 255.255.255.255
ISP1(config-if)#exit
ISP1(config)#interface Loopback1
ISP1(config-if)#ip address 209.165.201.30 255.255.255.255
ISP1(config-if)#exit
ISP1(config)#interface s1/0
ISP1(config-if)#ip address 209.165.201.1 255.255.255.252
ISP1(config-if)#no shutdown
ISP1(config-if)#exit
ISP1(config)#interface s1/1
ISP1(config-if)#ip address 209.165.200.225 255.255.255.252
ISP1(config-if)#no shutdown
ISP1(config-if)#exit
ISP1(config)#router eigrp 200
ISP1(config-router)#network 209.165.200.224
ISP1(config-router)#network 209.165.201.0
ISP1(config-router)#no auto-summary
ISP1(config-router)#exit
ISP1(config)#ip route 192.168.1.0 255.255.255.0 209.165.201.2
ISP1(config)#interface loopback 1
ISP1(config-if)#shut
ISP1(config)#interface loopback 1
ISP1(config-if)#no shutdown
ISP2 (R3)
Router>enable
Router#conf t
Router(config)#hostname ISP2
ISP2(config)#interface Loopback0
ISP2(config-if)#description Simulated Internet Web Server
ISP2(config-if)#ip address 209.165.200.254 255.255.255.255
ISP2(config-if)#exit
ISP2(config)#interface Loopback1
ISP2(config-if)#ip address 209.165.202.158 255.255.255.255
ISP2(config-if)#exit
ISP2(config)#interface s1/1
ISP2(config-if)#ip address 209.165.200.226 255.255.255.252
```

```

ISP2(config-if)#no shutdown
ISP2(config-if)#exit ISP2(config)#interface s1/0
ISP2(config-if)#ip address 20
9.165.202.129 255.255.255.252
ISP2(config-if)#no shutdown
ISP2(config-if)#exit
ISP2(config)#router eigrp 200
ISP2(config-router)#network 209.165.200.224
ISP2(config-router)#network 209.165.202.128
ISP2(config-router)#no auto-summary
ISP2(config-router)#exit
ISP2(config)#ip route 192.168.1.0 255.255.255.0 209.165.202.130

```

Practical 2

NETWORK TOPOLOGY

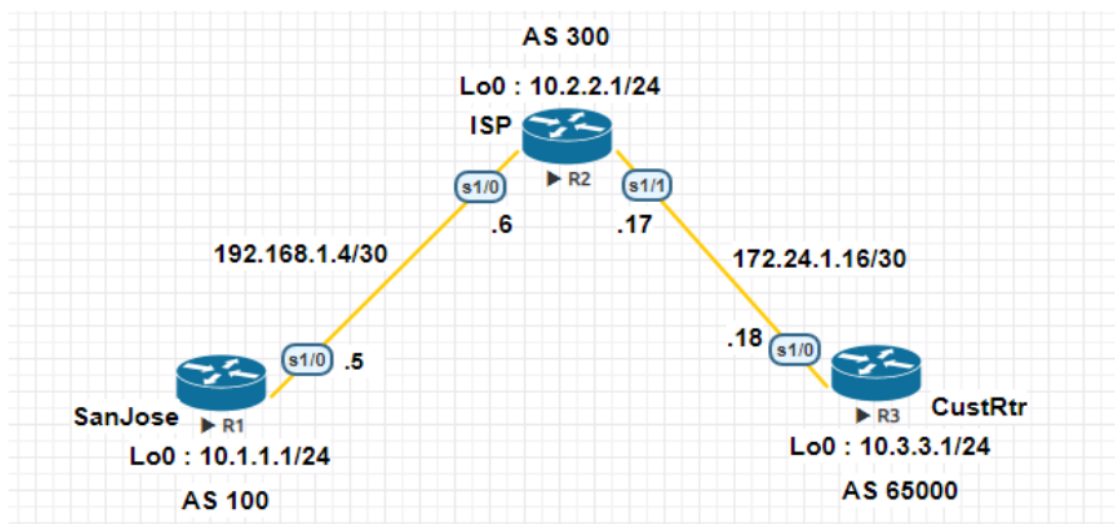

```

SanJose
Router>enable
Router#conf t
Router(config)#hostname SanJose
SanJose(config)#interface Loopback0
SanJose(config-if)#ip address 10.1.1.1 255.255.255.0
SanJose(config-if)#exit
SanJose(config)#interface Serial1/0
SanJose(config-if)#ip address 192.168.1.5 255.255.255.252
SanJose(config-if)#no shutdown
SanJose(config-if)#end
SanJose(config)#router bgp 100
SanJose(config-router)#network 10.1.1.0 mask 255.255.255.0
SanJose(config-router)#neighbor 192.168.1.6 remote-as 300
SanJose(config-router)#exit
SanJose#sh ip route

```

Codes: L - local, C - connected, S - static, R - RIP, M - mobile, B - BGP D - EIGRP, EX - EIGRP external, O - OSPF, IA - OSPF inter area N1 - OSPF NSSA external type 1, N2 - OSPF NSSA external type 2 E1 - OSPF external type 1, E2 - OSPF external type 2 i - IS-IS, su - IS-IS summary, L1 - IS-IS level-1, L2 - IS-IS level-2 ia - IS-IS inter area, * - candidate default, U - per-user static route o - ODR, P - periodic downloaded static route, H - NHRP, I - LISP a - application route + - replicated route, % - next hop override

Gateway of last resort is not set

10.0.0.0/8 is variably subnetted, 4 subnets, 2 masks

C 10.1.1.0/24 is directly connected, Loopback0

L 10.1.1.1/32 is directly connected, Loopback0

B 10.2.2.0/24 [20/0] via 192.168.1.6, 00:05:47

B 10.3.3.0/24 [20/0] via 192.168.1.6, 00:02:13 192.168.1.0/24 is variably subnetted, 2 subnets, 2 masks

C 192.168.1.4/30 is directly connected, Serial1/0

L 192.168.1.5/32 is directly connected, Serial1/0

SanJose#sh ip bgp

BGP table version is 4, local router ID is 10.1.1.1

Status codes: s suppressed, d damped, h history, * valid, > best, i - internal, r RIB-failure, S Stale, m multipath, b backup-path, f RT-Filter, x best-external, a additional-path, c RIB-compressed, Origin codes: i - IGP, e - EGP, ? - incomplete RPKI validation codes: V valid, I invalid, N Not found

Network	Next Hop	Metric	LocPrf Weight Path
*> 10.1.1.0/24	0.0.0.0	0	32768 i
*> 10.2.2.0/24	192.168.1.6	0	0 300 i
*> 10.3.3.0/24	192.168.1.6		0 300 65000 i

SanJose#sh ip bgp

BGP table version is 5, local router ID is 10.1.1.1

Status codes: s suppressed, d damped, h history, * valid, > best, i - internal, r RIB-failure, S Stale, m multipath, b backup-path, f RT-Filter, x best-external, a additional-path, c RIB-compressed, Origin codes: i - IGP, e - EGP, ? - incomplete RPKI validation codes: V valid, I invalid, N Not found

Network	Next Hop	Metric	LocPrf Weight t
*> 10.1.1.0/24	0.0.0.0	0	32768 i
*> 10.2.2.0/24	192.168.1.6	0	0 300 i
*> 10.3.3.0/24	192.168.1.6		0 300 i

ISP Router>enable

Router#conf t

Router(config)#hostname ISP

ISP(config)#interface Loopback0

ISP(config-if)#ip address 10.2.2.1 255.255.255.0

ISP(config-if)#exit ISP(config)#interface Serial1/0

ISP(config-if)#ip address 192.168.1.6 255.255.255.252 I

SP(config-if)#no shutdown

ISP(config-if)#exit

ISP(config)#interface Serial1/1

ISP(config-if)#ip address 172.24.1.17 255.255.255.252

```

ISP(config-if)#no shutdown
ISP(config-if)#end
ISP(config)#router bgp 300
ISP(config-router)#network 10.2.2.0 mask 255.255.255.0
ISP(config-router)#neighbor 192.168.1.5 remote-as 100
ISP(config-router)#neighbor 172.24.1.18 remote-as 65000
ISP(config)#router bgp 300
ISP(config-router)#neighbor 192.168.1.5 remove-private-as
ISP(config-router)#end
ISP#clear ip bgp * soft
ISP(config)#ip as-path access-list 1 deny ^100$ ISP(config)#ip as-path access-list 1 permit .*
ISP(config)#router bgp 300
ISP(config-router)#neighbor 172.24.1.18 filter-list 1 out
ISP(config-router)#end
ISP#sh ip route
Codes: L - local, C - connected, S - static, R - RIP, M - mobile, B - BGP D - EIGRP, EX - EIGRP
external, O - OSPF, IA - OSPF inter area N1 - OSPF NSSA external type 1, N2 - OSPF NSSA
external type 2 E1 - OSPF external type 1, E2 - OSPF external type 2 i - IS-IS, su - IS-IS
summary, L1 - IS-IS level-1, L2 - IS-IS level-2 ia - IS-IS inter area, * - candidate default, U - per-
user static route o - ODR, P - periodic downloaded static route, H - NHRP, I - LISP a -
application route + - replicated route, % - next hop override
Gateway of last resort is not set
10.0.0.0/8 is variably subnetted, 4 subnets, 2 masks
B 10.1.1.0/24 [20/0] via 192.168.1.5, 00:46:41
C 10.2.2.0/24 is directly connected, Loopback0
L 10.2.2.1/32 is directly connected, Loopback0
B 10.3.3.0/24 [20/0] via 172.24.1.18, 00:43:07 172.24.0.0/16 is variably subnetted, 2
subnets, 2 masks
C 172.24.1.16/30 is directly connected, Serial1/1
L 172.24.1.17/32 is directly connected, Serial1/1 192.168.1.0/24 is variably subnetted, 2
subnets, 2 masks
C 192.168.1.4/30 is directly connected, Serial1/0
L 192.168.1.6/32 is directly connected, Serial1/0
ISP#show ip bgp regexp ^100$
BGP table version is 4, local router ID is 10.2.2.1
Status codes: s suppressed, d damped, h history, * valid, > best, i - internal, r RIB-failure, S
Stale, m multipath, b backup-path, f RT-Filter, x best-external, a additional-path, c RIB-
compressed,
Origin codes: i - IGP, e - EGP, ? - incomplete
RPKI validation codes: V valid, I invalid, N Not found
Network          Next Hop          Metric          LocPrf Weight Pat
h *> 10.1.1.0/24  192.168.1.5      0                0 100 i
CustRtr
Router>enable
Router#conf t
Router(config)#hostname CustRtr
CustRtr(config)#interface Loopback0

```

```

CustRtr(config-if)#ip address 10.3.3.1 255.255.255.0
CustRtr(config-if)#exit
CustRtr(config)#interface Serial1/0
CustRtr(config-if)#ip address 172.24.1.18 255.255.255.252
CustRtr(config-if)#no shutdown
CustRtr(config-if)#end
CustRtr(config)#router bgp 65000
CustRtr(config-router)#network 10.3.3.0 mask 255.255.255.0
CustRtr(config-router)#neighbor 172.24.1.17 remote-as 30
0 CustRtr(config-router)#end
CustRtr#sh ip route
Codes: L - local, C - connected, S - static, R - RIP, M - mobile, B - BGP D - EIGRP, EX - EIGRP
external, O - OSPF, IA - OSPF inter area N1 - OSPF NSSA external type 1, N2 - OSPF NSSA
external type 2 E1 - OSPF external type 1, E2 - OSPF external type 2 i - IS-IS, su - IS-IS
summary, L1 - IS-IS level-1, L2 - IS-IS level-2 ia - IS-IS inter area, * - candidate default, U - per-
user static route o - ODR, P - periodic downloaded static route, H - NHRP, I - LISP a -
application route + - replicated route, % - next hop override
Gateway of last resort is not set
10.0.0.0/8 is variably subnetted, 3 subnets, 2 masks
B 10.2.2.0/24 [20/0] via 172.24.1.17, 00:45:59
C 10.3.3.0/24 is directly connected, Loopback0
L 10.3.3.1/32 is directly connected, Loopback0 172.24.0.0/16 is variably subnetted, 2
subnets, 2 mask
s C 172.24.1.16/30 is directly connected, Serial1/0
L 172.24.1.18/32 is directly connected, Serial1/0

```

Practical 3

NETWORK TOPOLOGY

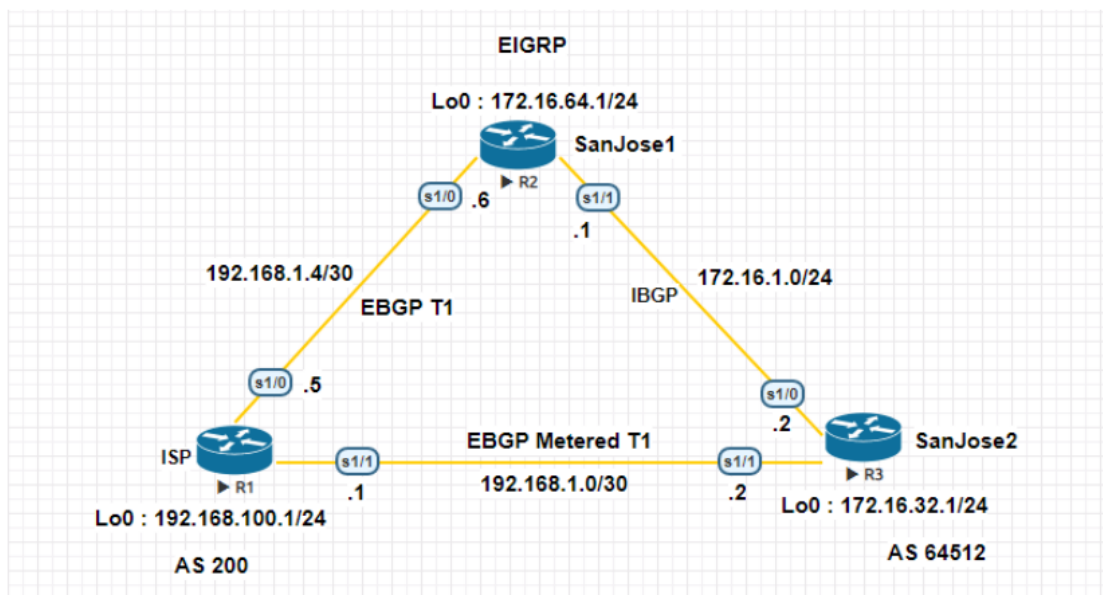

R1(ISP)

Router>enable

Router#conf t

Router(config)#hostname ISP

ISP(config)#interface Loopback0

ISP(config-if)#ip address 192.168.100.1 255.255.255.0

ISP(config-if)#exit

ISP(config)#interface Serial1/0

ISP(config-if)#ip address 192.168.1.5 255.255.255.252

ISP(config-if)#no shutdown

ISP(config-if)#exit

ISP(config)#interface Serial1/1

ISP(config-if)#ip address 192.168.1.1 255.255.255.252

ISP(config-if)#no shutdown

ISP(config-if)#exit

ISP(config)#router bgp 200

ISP(config-router)#network 192.168.100.0

ISP(config-router)#neighbor 192.168.1.6 remote-as 64512

ISP(config-router)#neighbor 192.168.1.2 remote-as 64512

ISP(config-router)#exit

ISP#sh ip bgp

BGP table version is 3, local router ID is 192.168.100.1

Status codes: s suppressed, d damped, h history, * valid, > best, i - internal, r RIB-failure, S Stale, m multipath, b backup-path, f RT-Filter, x best-external, a additional-path, c RIB-compressed,

Origin codes: i - IGP, e - EGP, ? - incomplete

RPKI validation codes: V valid, I invalid, N Not found

Network	Next Hop	Metric	LocPrf	Weight	Path
---------	----------	--------	--------	--------	------

```

* 172.16.0.0          192.168.1.2          0          0 64512 i
*> 192.168.1.6        0                    0          64512 i
*> 192.168.100.0     0.0.0.0              0          32768 i

```

ISP#ping 172.16.1.1 source 192.168.100.1

Type escape sequence to abort.

Sending 5, 100-byte ICMP Echos to 172.16.1.1, timeout is 2 seconds:

Packet sent with a source address of 192.168.100.1 !!!!!

Success rate is 100 percent (5/5), round-trip min/avg/max = 10/10/11 ms

ISP#ping 172.16.32.1 source 192.168.100.1

Type escape sequence to abort.

Sending 5, 100-byte ICMP Echos to 172.16.32.1, timeout is 2 seconds:

Packet sent with a source address of 192.168.100.1 !!!!!

Success rate is 100 percent (5/5), round-trip min/avg/max = 15/15/16 ms

ISP#ping 172.16.1.2 source 192.

168.100.1

Type escape sequence to abort.

Sending 5, 100-byte ICMP Echos to 172.16.1.2, timeout is 2 seconds:

Packet sent with a source address of 192.168.100.1 !!!!!

Success rate is 100 percent (5/5), round-trip min/avg/max = 15/17/25 ms

ISP(config)#router bgp 200

ISP(config-router)#network 192.168.1.0 mask 255.255.255.252

ISP(config-router)#network 192.168.1.4 mask 255.255.255.252

ISP(config-router)#exit

ISP#sh ip bgp

BGP table version is 5, local router ID is 192.168.100.1

Status codes: s suppressed, d damped, h history, * valid, > best, i - internal, r RIB-failure, S

Stale, m multipath, b backup-path, f RT-Filter, x best-external, a additional-path, c RIB-compressed,

Origin codes: i - IGP, e - EGP, ? - incomplete

RPKI validation codes: V valid, I invalid, N Not found

Network	Next Hop	Metric	LocPrf
Weight Path * 172.16.0.0	192.168.1.6	0	0 64512 i
*> 192.168.1.2	0	0	64512
i *> 192.168.1.0/30	0.0.0.0	0	32768 i
*> 192.168.1.4/30	0.0.0.0	0	32768 i
*> 192.168.100.0	0.0.0.0	0	32768

i

ISP#sh ip bgp

BGP table version is 6, local router ID is 192.168.100.1

Status codes: s suppressed, d damped, h history, * valid, > best, i - internal, r RIB-failure, S

Stale, m multipath, b backup-path, f RT-Filter, x best-external, a additional-path, c RIB-compressed,

Origin codes: i - IGP, e - EGP, ? - incomplete

RPKI validation codes: V valid, I invalid, N Not found

Network	Next Hop	Metric	LocPrf
Weight Path * > 172.16.0.0	192.168.1.6		50
0 64512 i			
* 192.168.1.2	75	0	
64512 i			
* > 192.168.1.0/30	0.0.0.0	0	
32768 i			
* > 192.168.1.4/30	0.0.0.0	0	
32768 i			
* > 192.168.100.0	0.0.0.0	0	
32768 i			

ISP#ping 172.16.1.1

Type escape sequence to abort.

Sending 5, 100-byte ICMP Echos to 172.16.1.1, timeout is 2 seconds: !!!!!

Success rate is 100 percent (5/5), round-trip min/avg/max = 9/10/11 ms

ISP#ping 172.16.1.2

Type escape sequence to abort.

Sending 5, 100-byte ICMP Echos to 172.16.1.2, timeout is 2 seconds: !!!!!

Success rate is 100 percent (5/5), round-trip min/avg/max = 20/21/25 ms

ISP#traceroute 172.16.1.1

Type escape sequence to abort.

Tracing the route to 172.16.1.1

VRF info: (vrf in name/id, vrf out name/id)

1 192.168.1.6 10 msec 10 msec *

ISP#traceroute 172.16.1.2

Type escape sequence to abort.

Tracing the route to 172.16.1.2

VRF info: (vrf in name/id, vrf out name/id)

1 192.168.1.6 10 msec 10 msec 13 msec

2 172.16.1.2 [AS 64512] 20 msec 19 msec

* R2 (SanJose1)

Router>enable Router#conf t

Router(config)#hostname SanJose1

SanJose1(config)#interface Loopback0

SanJose1(config-if)#ip address 172.16.64.1 255.255.255.0

SanJose1(config-if)#ip address 172.16.64.1 255.255.255.0

SanJose1(config-if)#exit

SanJose1(config)#interface Serial1/0

SanJose1(config-if)#ip address 192.168.1.6 255.255.255.252

SanJose1(config-if)#no shutdown

SanJose1(config-if)#exit

SanJose1(config)#interface Serial1/1

SanJose1(config-if)#ip address 172.16.1.1 255.255.255.0

SanJose1(config-if)#no shutdown

SanJose1(config-if)#exit

SanJose1(config)#router eigrp 64512

SanJose1(config-router)#network 172.16.0.0

```

SanJose1(config-router)#no auto-summary
SanJose1(config-router)#exit
SanJose1(config)#router bgp 64512
SanJose1(config-router)#neighbor 172.16.32.1 remote-as 64512
SanJose1(config-router)#neighbor 172.16.32.1 update-source loopback0
SanJose1(config-router)#exit
SanJose1(config)#ip route 172.16.0.0 255.255.0.0 null 0
SanJose1(config)#router bgp 64512
SanJose1(config-router)#network 172.16.0.0
SanJose1(config-router)#neighbor 192.168.1.5 remote-as 200 S
SanJose1(config-router)#exit
SanJose1(config)#router bgp 64512
SanJose1(config-router)#neig
hbor 172.16.32.1 next-hop-self
SanJose1(config-router)#exit
SanJose1#sh ip bgp
BGP table version is 5, local router ID is 172.16.64.1
Status codes: s suppressed, d damped, h history, * valid, > best, i - internal, r RIB-failure, S
Stale, m multipath, b backup-path, f RT-Filter, x best-external, a additional-path, c RIB-
compressed, Origin codes: i - IGP, e - EGP, ? - incomplete
RPKI validation codes: V valid, I invalid, N Not found
Network          Next Hop          Metric          LocPrf
Weight Path * i 172.16.0.0          172.16.32.1          0
100 0 i
*> 0.0.0.0          0          32768 i
* i 192.168.1.0/30 172.16.32.1          0          100          0 200 i
*> 192.168.1.5 0 0 200 i r i 192.168.1.4/30 172.16.32.1 0 100 0          200 i
r> 192.168.1.5 0 0 200 i
* i 192.168.100.0 172.16.32.1          0          100          0 200 i
*> 192.168.1.5          0          0          200 i
SanJose1(config)#route-map PRIMARY_T1_IN permit 10
SanJose1(config-route-map)#set local-preference 160
SanJose1(config-route-map)#exit
SanJose1(config)#router bgp 64512
SanJose1(config-router)#neighbor 192.168.1.5 route-map PRIMARY_T1_IN in
SanJose1(config-router)#exit
SanJose1#clear ip bgp * soft
SanJose1#sh ip bgp
BGP table version is 8, local router ID is 172.16.64.1
Status codes: s suppressed, d damped, h history, * valid, > best, i - internal, r RIB-failure, S
Stale, m multipath, b backup-path, f RT-Filter, x best-external, a additional-path, c RIB-
compressed, Origin codes: i - IGP, e - EGP, ? - incomplete
RPKI validation codes: V valid, I invalid, N Not found
Network          Next Hop          Metric          LocPrf
Weight Path * i 172.16.0.0          172.16.32.1          0
100 0 i
*> 0.0.0.0          0          32768

```

```

i *> 192.168.1.0/30          192.168.1.5          0          160 0
200 i
r> 192.168.1.4/30 192.168.1.5    0          160          0
200 i
*> 192.168.100.0          192.168.1.5          0          160 0
200 i

```

```

SanJose1(config)#route-map PRIMARY_T1_MED_OUT permit 10
SanJose1(config-route-map)#set Metric 50
SanJose1(config-route-map)#exit
SanJose1(config)#router bgp 64512
SanJose1(config-router)#neighbor 192.168.1.5 route-map PRIMARY_T1_MED_OUT out
SanJose1(config-router)#exit
SanJose1(config)#exit

```

```
SanJose1#clear ip bgp * soft
```

```
SanJose1#sh ip bgp
```

```
BGP table version is 8, local router ID is 172.16.64.1
```

```
Status codes: s suppressed, d damped, h history, * valid, > best, i - internal, r RIB-failure, S
Stale, m multipath, b backup-path, f RT-Filter, x best-external, a additional-path, c RIB-
compressed, Origin codes: i - IGP, e - EGP, ? - incomplete
```

```
RPKI validation codes: V valid, I invalid, N Not found
```

Network	Next Hop	Metric	LocPrf
Weight Path * i 172.16.0.0	172.16.32.1	0	
100 0 i			
*> 0.0.0.0	0		
32768 i			
*> 192.168.1.0/30	192.168.1.5	0	160
0 200 i			
r> 192.168.1.4/30	192.168.1.5	0	160
0 200 i			
*> 192.168.100.0	192.168.1.5	0	
160 0 200 i			

```
SanJose1#sh ip route
```

```
Codes: L - local, C - connected, S - static, R - RIP, M - mobile, B - BGP D - EIGRP, EX - EIGRP
external, O - OSPF, IA - OSPF inter area N1 - OSPF NSSA external type 1, N2 - OSPF NSSA
external type 2 E1 - OSPF external type 1, E2 - OSPF external type 2 i - IS-IS, su - IS-IS
summary, L1 - IS-IS level-1, L2 - IS-IS level-2 ia - IS-IS inter area, * - candidate default, U - per-
user static route o - ODR, P - periodic downloaded static route, H - NHRP, I - LISP a -
application route + - replicated route, % - next hop override
```

```
Gateway of last resort is not set
```

```
172.16.0.0/16 is variably subnetted, 6 subnets, 3 masks
```

```
S 172.16.0.0/16 is directly connected, Null0
```

```
C 172.16.1.0/24 is directly connected, Serial1/1
```

```
L 172.16.1.1/32 is directly connected, Serial1/1
```

```
D 172.16.32.0/24 [90/2297856] via 172.16.1.2, 01:28:25, Serial1/1
```

```
C 172.16.64.0/24 is directly connected, Loopback0
```

```

L 172.16.64.1/32 is directly connected, Loopback0 192.168.1.0/24 is variably subnetted, 3
subnets, 2 masks
B 192.168.1.0/30 [20/0] via 192.168.1.5, 00:45:28
C 192.168.1.4/30 is directly connected, Serial1/0
L 192.168.1.6/32 is directly connected, Serial1/0
B 192.168.100.0/24 [20/0] via 192.168.1.5, 00:45:28
After issuing ip default-network
SanJose1(config)#ip default-network 192.168.100.0
SanJose1(config)#end SanJose1#sh ip route
Codes: L - local, C - connected, S - static, R - RIP, M - mobile, B - BGP D - EIGRP, EX - EIGRP
external, O - OSPF, IA - OSPF inter area N1 - OSPF NSSA external type 1, N2 - OSPF NSSA
external type 2 E1 - OSPF external type 1, E2 - OSPF external type 2 i - IS-IS, su - IS-IS
summary, L1 - IS-IS level-1, L2 - IS-IS level-2 ia - IS-IS inter area, * - candidate default, U - per-
user static route o - ODR, P - periodic downloaded static route, H - NHRP, I - LISP a -
application route + - replicated route, % - next hop override
Gateway of last resort is 192.168.1.5 to network 192.168.100.0
S* 0.0.0.0/0 [20/0] via 192.168.1.5 172.16.0.0/16 is variably subnetted, 6 subnets, 3 masks
S 172.16.0.0/16 is directly connected, Null0
C 172.16.1.0/24 is directly connected, Serial1/1
L 172.16.1.1/32 is directly connected, Serial1/1
D 172.16.32.0/24 [90/2297856] via 172.16.1.2, 01:33:38, Serial1/1
C 172.16.64.0/24 is directly connected, Loopback0
L 172.16.64.1/32 is directly connected, Loopback0 192.168.1.0/24 is variably subnetted, 3
subnets, 2 masks
B 192.168.1.0/30 [20/0] via 192.168.1.5, 00:50:41
C 192.168.1.4/30 is directly connected, Serial1/0
L 192.168.1.6/32 is directly connected, Serial1/0
B* 192.168.100.0/24 [20/0] via 192.168.1.5, 00:50:41
SanJose1#ping 192.168.1.2
Type escape sequence to abort.
Sending 5, 100-byte ICMP Echos to 192.168.1.2, timeout is 2 seconds: !!!!!
Success rate is 100 percent (5/5), round-trip min/avg/max = 14/15/16 ms
SanJose1#traceroute 192.168.1.2
Type escape sequence to abort.
Tracing the route to 192.168.1.2
VRF info: (vrf in name/id, vrf out name/id) 1 192.168.1.5 [AS 200] 10 msec 10 msec 10 msec
2 192.168.1.2 [AS 200] 15 msec 15 msec *
SanJose1#ping 192.168.1.1
Type escape sequence to abort.
Sending 5, 100-byte ICMP Echos to 192.168.1.1, timeout is 2 seconds: !!!!!
Success rate is 100 percent (5/5), round-trip min/avg/max = 9/9/11 ms
SanJose1#traceroute 192.168.1.1
Type escape sequence to abort.
Tracing the route to 192.168.1.1
VRF info: (vrf in name/id, vrf out name/id)
1 192.168.1.5 [AS 200] 10 msec 11 msec *
R3 (SanJose2)

```

```

Router>en
Router#conf t
Router(config)#hostname SanJose2
SanJose2(config)#interface Loopback0
SanJose2(config-if)#ip address 172.16.32.1 255.255.255.0
SanJose2(config-if)#exit
SanJose2(config)#interface Serial1/1
SanJose2(config-if)#ip address 192.168.1.2 255.255.255.252
SanJose2(config-if)#no shutdown
SanJose2(config-if)#exit
SanJose2(config)#interface Serial1/0
SanJose2(config-if)#ip address 172.16.1.2 255.255.255.0
SanJose2(config-if)#no shutdown
SanJose2(config-if)#exit
SanJose2(config)#router eigrp 64512
SanJose2(config-router)#network 172.16.0.0
SanJose2(config-router)#no auto-summary
SanJose2(config-router)#exit
SanJose2(config)#router bgp 64512
SanJose2(config-router)#neighbor 172.16.64.1 remote-as 64512
SanJose2(config-router)#neighbor 172.16.64.1 update-source loopback0
SanJose2(config-router)#exit
SanJose2(config)#ip route 172.16.0.0 255.255.0.0 null 0
SanJose2(config)#router bgp 64512
SanJose2(config-router)#network 172.16.0.0
SanJose2(config-router)#neighbor 192.168.1.1 remote-as 200
SanJose2(config-router)#exit
SanJose2#sh ip bgp summary
BGP router identifier 172.16.32.1, local AS number 64512
BGP table version is 4, main routing table version 4
2 network entries using 280 bytes of memory
4 path entries using 320 bytes of memory 4/2 BGP path/bestpath attribute entries using
576 bytes of memory
1 BGP AS-PATH entries using 24 bytes of memory
0 BGP route-map cache entries using 0 bytes of memory 0
BGP filter-list cache entries using 0 bytes of memory
BGP using 1200 total bytes of memory
BGP activity 2/0 prefixes, 4/0 paths, scan interval 60 secs Neighbor V AS MsgRcvd MsgSent
TbIVer InQ OutQ Up/Down State/PfxRcd 172.16.64.1 4 64512 31 32 4 0 0 00:24:41 2
192.168.1.1 4 200 8 6 4 0 0 00:01:22 1
SanJose2#sh ip route
Codes: L - local, C - connected, S - static, R - RIP, M - mobile, B - BGP D - EIGRP, EX - EIGRP
external, O - OSPF, IA - OSPF inter area N1 - OSPF NSSA external type 1, N2 - OSPF NSSA
external type 2 E1 - OSPF external type 1, E2 - OSPF external type 2 i - IS-IS, su - IS-IS
summary, L1 - IS-IS level-1, L2 - IS-IS level-2 ia - IS-IS inter area, * - candidate default, U - per-
user static route o - ODR, P - periodic downloaded static route, H - NHRP, I - LISP a -
application route + - replicated route, % - next hop override

```

```

Gateway of last resort is not set
172.16.0.0/16 is variably subnetted, 6 subnets, 3 masks
S 172.16.0.0/16 is directly connected, Null0
C 172.16.1.0/24 is directly connected, Serial1/0 L 172.16.1.2/32 is directly connected,
Serial1/0 C 172.16.32.0/24 is directly connected, Loopback0
L 172.16.32.1/32 is directly connected, Loopback0
D 172.16.64.0/24 [90/2297856] via 172.16.1.1, 00:08:46, Serial1/0 192.168.1.0/24 is
variably subnetted, 3 subnets, 2 mask
s C 192.168.1.0/30 is directly connected, Serial1/1
L 192.168.1.2/32 is directly connected, Serial1/1
B 192.168.1.4/30 [20/0] via 192.168.1.1, 00:02:19
B 192.168.100.0/24 [20/0] via 192.168.1.1, 00:07:40
SanJose2#sh ip bgp
BGP table version is 5, local router ID is 172.16.32.1
Status codes: s suppressed, d damped, h history, * valid, > best, i - internal, r RIB-failure, S
Stale, m multipath, b backup-path, f RT-Filter, x best-external, a additional-path, c RIB-
compressed, Origin codes: i - IGP, e - EGP, ? - incomplete
RPKI validation codes: V valid, I invalid, N Not found
Network          Next Hop          Metric           LocPrf
Weight Path * i 172.16.0.0          172.16.64.1          0
100 0 i
*> 0.0.0.0 0 32768 i r i 192.168.1.0/30 192.168.1.5    0                100 0
200 i
r> 192.168.1.1 0 0 200 i
* i 192.168.1.4/30          192.168.1.5    0                100 0
200 i
*> 192.168.1.1              0                0
200 i
* i 192.168.100.0 192.168.1.5    0                100
0 200 i
*> 192.168.1.1              0                0
200 i SanJose2(config)#router bgp 64512
SanJose2(config-router)#neighbor 172.16.64.1 next-hop-self
SanJose2(config-router)#exi
t SanJose2#sh ip bgp
BGP table version is 5, local router ID is 172.16.32.1
Status codes: s suppressed, d damped, h history, * valid, > best, i - internal, r RIB-failure, S
Stale, m multipath, b backup-path, f RT-Filter, x best-external, a additional-path, c RIB-
compressed, Origin codes: i - IGP, e - EGP, ? - incomplete
RPKI validation codes: V valid, I invalid, N Not found Network Next Hop Metric LocPrf
Weight Path * i 172.16.0.0 172.16.64.1 0 100 0 i *> 0.0.0.0 0 32768 i r i 192.168.1.0/30
172.16.64.1 0 100 0 200 i r> 192.168.1.1 0 0 200 i * i 192.168.1.4/30 172.16.64.1 0 100 0
200 i *> 192.168.1.1 0 0 200 i * i 192.168.100.0 172.16.64.1 0 100 0 200 i *> 192.168.1.1 0 0
200 i
SanJose2(config)#route-map SECONDARY_T1_IN permit 10
SanJose2(config-route-map)#set local-preference 125
SanJose2(config-route-map)#exi

```

```

t SanJose2(config)#router bgp 64512
SanJose2(config-router)#neighbor 192.168.1.1 route-map SECONDARY_T1_IN in
SanJose2(config-router)#exit
SanJose2#clear ip bgp * soft
SanJose2#sh ip bgp
BGP table version is 8, local router ID is 172.16.32.1 Status codes: s suppressed, d damped, h
history, * valid, > best, i - internal, r RIB-failure, S Stale, m multipath, b backup-path, f RT-
Filter, x best-external, a additional-path, c RIB-compressed, Origin codes: i - IGP, e - EGP, ? -
incomplete
RPKI validation codes: V valid, I invalid, N Not found Network Next Hop Metric LocPrf
Weight Path * i 172.16.0.0 172.16.64.1 0 100 0 i *> 0.0.0.0 0 32768 i r>i 192.168.1.0/30
172.16.64.1 0 160 0 200 i r 192.168.1.1 0 125 0 200 i *>i 192.168.1.4/30 172.16.64.1 0 160 0
200 i * 192.168.1.1 0 125 0 200 i *>i 192.168.100.0 172.16.64.1 0 160 0 200 i * 192.168.1.1 0
125 0 200 i
SanJose2(config)#route-map SECONDARY_T1_MED_OUT permit 10
SanJose2(config-route-map)#set Metric 75
SanJose2(config-route-map)#exit
SanJose2(config)#router bgp 64512
SanJose2(config-router)#$2.168.1.1 route-map SECONDARY_T1_MED_OUT out
SanJose2(config-router)#end
SanJose2#clear ip bgp * soft
SanJose2#sh ip bgp
BGP table version is 8, local router ID is 172.16.32.1 Status codes: s suppressed, d damped, h
history, * valid, > best, i - internal, r RIB-failure, S Stale, m multipath, b backup-path, f RT-
Filter, x best-external, a additional-path, c RIB-compressed, Origin codes: i - IGP, e - EGP, ? -
incomplete
RPKI validation codes: V valid, I invalid, N Not found

```

Network	Next Hop	Metric	LocPrf
Weight Path * i 172.16.0.0	172.16.64.1		0
100 0 i			
*> 0.0.0.0	0		32768
i			
r>i 192.168.1.0/30	172.16.64.1	0	160 0
200 i			
r 192.168.1.1 0	125	0	200
i			
*>i 192.168.1.4/30	172.16.64.1	0 160 0	
200 i			
* 192.168.1.1 0	125	0	
200 i			
*>i 192.168.100.0 172.16.64.1	0	160	0
200 i			
* 192.168.1.1	0	125	0
200 i			

Practical 4

NETWORK TOPOLOGY

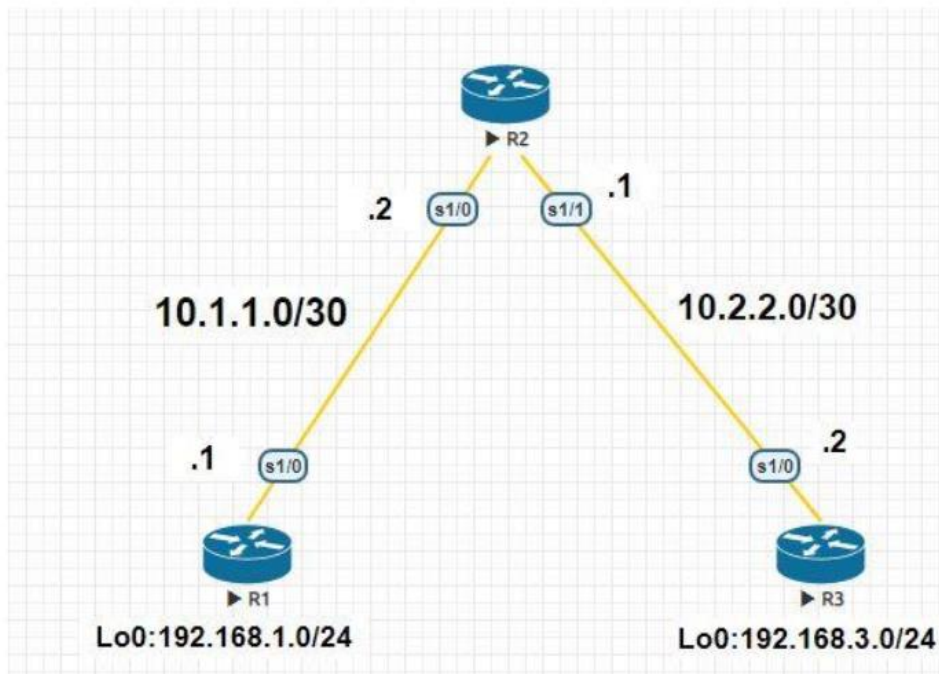

```
R1 Router>en
Router#conf t
Enter configuration commands, one per line. End with CNTL/Z.
Router(config)#hostname R1
R1(config)#interface Loopback 0
*Dec 19 07:53:42.473: %LINEPROTO-5-UPDOWN: Line protocol on Interface Loopback0,
changed state to up
R1(config-if)#ip address 192.168.1.1 255.255.255.0
R1(config-if)#exit
R1(config)#interface s1/0
R1(config-if)#ip address 10.1.1.1 255.255.255.252
R1(config-if)#no shutdown
*Dec 19 07:57:21.998: %LINK-3-UPDOWN: Interface Serial1/0, changed state to up
```

```
*Dec 19 07:57:22.999: %LINEPROTO-5-UPDOWN: Line protocol on Interface Serial1/0,
changed state to up
R1(config-if)#exit
```

```
R1(config)#exit Configure static routes a.
```

```
On R1, configure a default static route to ISP.
```

```
R1(config)# ip route 0.0.0.0 0.0.0.0 10.1.1.2
```

```
R1#show ip route
```

```
Codes: L - local, C - connected, S - static, R - RIP, M - mobile, B - BGP D - EIGRP, EX - EIGRP
external, O - OSPF, IA - OSPF inter area N1 - OSPF NSSA external type 1, N2 - OSPF NSSA
external type 2 E1 - OSPF external type 1, E2 - OSPF external type 2 i - IS-IS, su - IS-IS
summary, L1 - IS-IS level-1, L2 - IS-IS level-2 ia - IS-IS inter area, * - candidate default,U - per-
user static route o - ODR, P - periodic downloaded static route,H - NHRP,I - LISP a -
application route + - replicated route, % - next hop override
```

```
Gateway of last resort is 10.1.1.2 to network 0.0.0.0
```

```
S* 0.0.0.0/0 [1/0] via 10.1.1.2 10.0.0.0/8 is variably subnetted, 2 subnets, 2 masks
```

```
C 10.1.1.0/30 is directly connected, Serial1/0
```

```
L 10.1.1.1/32 is directly connected, Serial1/0 192.168.1.0/24 is variably subnetted, 2
subnets, 2 masks
```

```
C 192.168.1.0/24 is directly connected, Loopback0
```

```
L 192.168.1.1/32 is directly connected, Loopback0 Secure management access
```

```
R1(config)#security passwords min-length 10
```

```
R1(config)#enable secret class12345
```

```
R1(config)#line console 0
```

```
R1(config-line)#password ciscoconpass
```

```
R1(config-line)#exec-timeout 5 0
```

```
R1(config-line)#login
```

```
R1(config-line)#logging synchronous
```

```
R1(config-line)#exit
```

```
R1(config)#line vty 0 4
```

```
R1(config-line)#password ciscovtypass
```

```
R1(config-line)#exec-timeout 5 0
```

```
R1(config-line)#login
```

```
R1(config-line)#exit
```

```
R1(config)#line aux 0
```

```
R1(config-line)#no exec
```

```
R1(config-line)#end
```

```
R1(config)#service password-encryption
```

```
R1(config)#banner motd $Unauthorized access strictly prohibited!$
```

```
R1(config)#exit Configure enhanced username password security
```

```
R1(config)#username JR-ADMIN secret class12345
```

```
R1(config)#username ADMIN secret class54321
```

```
R1(config)#line console 0
```

```
R1(config-line)#login local
```

```
R1(config-line)#end
```

```
R1(config)#line vty 0 4
```

```

R1(config-line)#login local
R1(config-line)#end Enabling AAA RADIUS Authentication with Local User for Backup
R1(config)# aaa new-model
R1(config)# radius server RADIUS-1
R1(config-radius-server)# address ipv4 192.168.1.101
R1(config-radius-server)# key RADIUS-1-pa55w0rd
R1(config-radius-server)# exit
R1(config)# radius server RADIUS-2
R1(config-radius-server)# address ipv4 192.168.1.102
R1(config-radius-server)# key RADIUS-2-pa55w0rd
R1(config-radius-server)# exit
R1(config)# aaa group server radius RADIUS-GROUP
R1(config-sg-radius)# server name RADIUS-1
R1(config-sg-radius)# server name RADIUS-2
R1(config-sg-radius)# exit
R1(config)# aaa authentication login default group RADIUS-GROUP local
R1(config)# aaa authentication login TELNET-LOGIN group RADIUS-GROUP localcase
R1(config)# line vty 0 4
R1(config-line)# login authentication TELNET-LOGIN
R1(config-line)# exit
R2 Router>enable
Router#conf t Enter configuration commands, one per line. End with CNTL/Z.
Router(config)#hostname R2
R2(config)#interface s1/0
R2(config-if)#ip address 10.1.1.2 255.255.255.252
R2(config-if)#no shutdown
*Dec 19 08:01:10.279: %LINK-3-UPDOWN: Interface Serial1/0, changed state to up *Dec 19
08:01:11.279: %LINEPROTO-5-UPDOWN: Line protocol on Interface Serial1/0, changed state
to up R2(config-if)#exit
R2(config)#interface s1/1
R2(config-if)#ip address 10.2.2.1 255.255.255.252
R2(config-if)#no shutdown
*Dec 19 08:02:33.002: %LINK-3-UPDOWN: Interface Serial1/1, changed state to up
*Dec 19 08:02:34.009: %LINEPROTO-5-UPDOWN: Line protocol on Interface Serial1/1,
changed state to up
R2(config-if)#exit
R2(config)#exit Configure static routes a. On R2, configure two static routes.
R2(config)# ip route 192.168.1.0 255.255.255.0 10.1.1.1
R2(config)# ip route 192.168.3.0 255.255.255.0 10.2.2.2
R2#show ip route Codes: L - local, C - connected, S - static, R - RIP, M - mobile, B - BGP D -
EIGRP, EX - EIGRP external, O - OSPF, IA - OSPF inter area N1 - OSPF NSSA external type 1, N2
- OSPF NSSA external type 2 E1 - OSPF external type 1, E2 - OSPF external type 2 i - IS-IS, su -
IS-IS summary, L1 - IS-IS level-1, L2 - IS-IS level-2 ia - IS-IS inter area, * - candidate default, U -
per-user static route o - ODR, P - periodic downloaded static route, H - NHRP, I - LISP a -
application route + - replicated route, % - next hop override
Gateway of last resort is not set 10.0.0.0/8 is variably subnetted, 4 subnets, 2 mask

```

```
s C 10.1.1.0/30 is directly connected, Serial1/0 L 10.1.1.2/32 is directly connected, Serial1/0
C 10.2.2.0/30 is directly connected, Serial1/1
L 10.2.2.1/32 is directly connected, Serial1/1
S 192.168.1.0/24 [1/0] via 10.1.1.1
S 192.168.3.0/24 [1/0] via 10.2.2.2 Secure management access
R2(config)#security passwords min-length 10
R2(config)#enable secret class12345
R2(config)#line console 0 R2(config-line)#password ciscoconpass
R2(config-line)#exec-timeout 5 0
R2(config-line)#login
R2(config-line)#logging synchronous
R2(config-line)#exit
R2(config)#line vty 0 4
R2(config-line)#password ciscovtypass
R2(config-line)#exec-timeout 5 0
R2(config-line)#login
R2(config-line)#exit
R2(config)#line aux 0
R2(config-line)#no exec
R2(config-line)#end
R2(config)#service password-encryption
R2(config)#banner motd $Unauthorized access strictly prohibited!$
R2(config)#exit Configure enhanced username password security
R2(config)#username JR-ADMIN secret class12345
R2(config)#username ADMIN secret class54321
R2(config)#line console 0
R2(config-line)#login local
R2(config-line)#end
R2(config)#line vty 0 4
R2(config-line)#login local
R2(config-line)#end Enabling AAA RADIUS Authentication with Local User for Backup
R2(config)# aaa new-model
R2(config)# radius server RADIUS-1
R2(config-radius-server)# address ipv4 192.168.1.101
R2(config-radius-server)# key RADIUS-1-pa55w0rd
R2(config-radius-server)# exit
R2(config)# radius server RADIUS-2
R2(config-radius-server)# address ipv4 192.168.1.102
R2(config-radius-server)# key RADIUS-2-pa55w0rd
R2(config-radius-server)# exit R2(config)# aaa group server radius RADIUS-GROUP
R2(config-sg-radius)# server name RADIUS-1
R2(config-sg-radius)# server name RADIUS-2
R2(config-sg-radius)# exit
R2(config)# aaa authentication login default group RADIUS-GROUP local
R2(config)# aaa authentication login TELNET-LOGIN group RADIUS-GROUP localcase
R2(config)# line vty 0 4
R2(config-line)# login authentication TELNET-LOGIN
```

```
R2(config-line)# exit
R3 Router>enable
Router#conf t Enter configuration commands, one per line. End with CNTL/Z.
Router(config)#hostname R3
R3(config)#interface loopback 0
*Dec 19 08:07:50.079: %LINEPROTO-5-UPDOWN: Line protocol on Interface Loopback0,
changed state to up
R3(config-if)#ip address 192.168.3.1 255.255.255.0
R3(config-if)#exit
R3(config)#interface s1/0
R3(config-if)#ip address 10.2.2.2 255.255.255.252
R3(config-if)#no shutdown
R3(config-if)#exit
*Dec 19 08:09:26.986: %LINK-3-UPDOWN: Interface Serial1/0, changed state to up
*Dec 19 08:09:27.996: %LINEPROTO-5-UPDOWN: Line protocol on Interface Serial1/0,
changed state to up
R3(config)#end Configure static routes a. On R3, configure a default static route to ISP.
R3(config)# ip route 0.0.0.0 0.0.0.0 10.2.2.1
R3#show ip route Codes: L - local, C - connected, S - static, R - RIP, M - mobile, B - BGP D -
EIGRP, EX - EIGRP external, O - OSPF, IA - OSPF inter area N1 - OSPF NSSA external type 1, N2
- OSPF NSSA external type 2 E1 - OSPF external type 1, E2 - OSPF external type 2 i - IS-IS, su
- IS-IS summary, L1 - IS-IS level-1, L2 - IS-IS level-2 ia - IS-IS inter area, * - candidate default, U -
per-user static route o - ODR, P - periodic downloaded static route, H - NHRP, I - LISP a -
application route + - replicated route, % - next hop override
Gateway of last resort is 10.2.2.1 to network 0.0.0.0
S* 0.0.0.0/0 [1/0] via 10.2.2.1 10.0.0.0/8 is variably subnetted, 2 subnets, 2 masks
C 10.2.2.0/30 is directly connected, Serial1/0
L 10.2.2.2/32 is directly connected, Serial1/0 192.168.3.0/24 is variably subnetted, 2
subnets, 2 masks
C 192.168.3.0/24 is directly connected, Loopback0
L 192.168.3.1/32 is directly connected, Loopback0 Secure management access
R3(config)#security passwords min-length 10
R3(config)#enable secret class12345
R3(config)#line console 0
R3(config-line)#password ciscoconpass
R3(config-line)#exec-timeout 5 0
R3(config-line)#login
R3(config-line)#logging synchronous
R3(config-line)#exit
R3(config)#line vty 0 4
R3(config-line)#password ciscovtypass
R3(config-line)#exec-timeout 5 0
R3(config-line)#login R3(config-line)#exit
R3(config)#line aux 0
R3(config-line)#no exec
R3(config-line)#end
R3(config)#service password-encryption
```

```
R3(config)#banner motd $Unauthorized access strictly prohibited!$ Configure enhanced
username password security
R3(config)#username JR-ADMIN secret class12345
R3(config)#username ADMIN secret class54321
R3(config)#line console 0
R3(config-line)#login local
R3(config-line)#exit
R3(config)#line vty 0 4
R3(config-line)#login local
R3(config-line)#exit
Enabling AAA RADIUS Authentication with Local User for Backup
R3(config)# aaa new-model
R3(config)# radius server RADIUS-1
R3(config-radius-server)# address ipv4 192.168.1.101
R3(config-radius-server)# key RADIUS-1-pa55w0rd
R3(config-radius-server)# exit
R3(config)# radius server RADIUS-2
R3(config-radius-server)# address ipv4 192.168.1.102
R3(config-radius-server)# key RADIUS-2-pa55w0rd
R3(config-radius-server)# exit
R3(config)# aaa group server radius RADIUS-GROUP
R3(config-sg-radius)# server name RADIUS-1
R3(config-sg-radius)# server name RADIUS-2 R3(config-sg-radius)# exit
R3(config)# aaa authentication login default group RADIUS-GROUP loca
l R3(config)# aaa authentication login TELNET-LOGIN group RADIUS-GROUP localcase
R3(config)# line vty 0 4
R3(config-line)# login authentication TELNET-LOGIN
R3(config-line)# exit
```

Practical 5

NETWORK TOPOLOGY

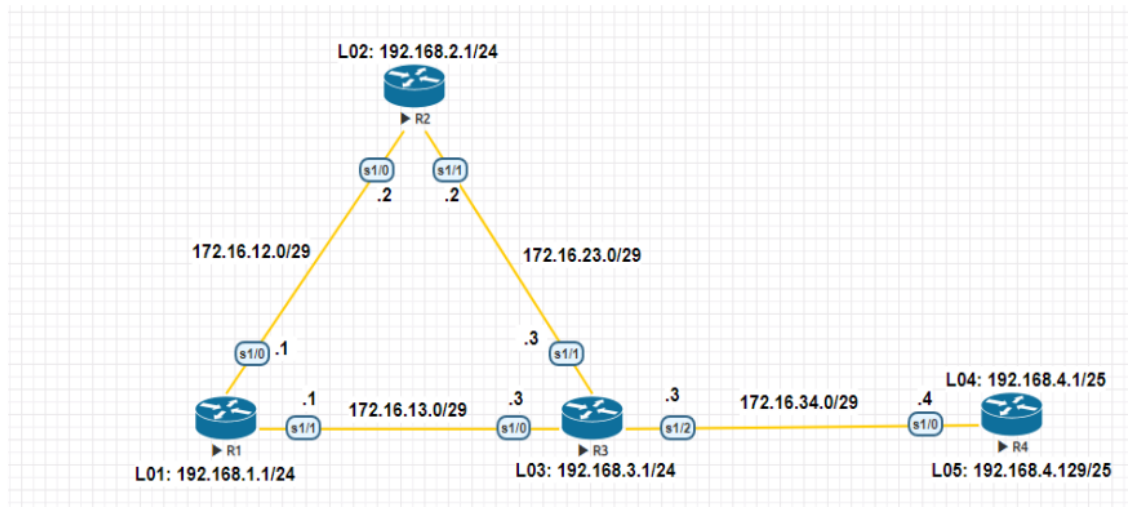

R1 Router>enable

Router#conf t Enter configuration commands, one per line. End with CNTL/Z.

Router(config)#hostname R1

R1(config)#interface Lo1

R1(config-if)#ip address 192.168.1.1 255.255.255.0

R1(config-if)#exit

R1(config)#interface s1/0

R1(config-if)#ip address 172.16.12.1 255.255.255.248

R1(config-if)#no shutdown

R1(config-if)#exit R1(config)#interface s1/1

R1(config-if)#ip address 172.16.13.1 255.255.255.248 R1(config-if)#no shutdown

R1(config-if)#exit

R1(config)#router eigrp 100

R1(config-router)#network 192.168.1.0

R1(config-router)#network 172.16.12.0

R1(config-router)#network 172.16.13.0

R1(config-router)#no auto-summary

R1(config-router)#exit

R1#sh ip eigrp neighbors

EIGRP-IPv4 Neighbors for AS(100) H Address Interface Hold Uptime SRTT RTO Q Seq (sec)

(ms) Cnt Num 1 172.16.13.3 Se1/1 14 00:04:43 11 100 0 10 0 172.16.12.2 Se1/0 12 00:07:05
19 114 0 8

R1#sh ip route

Codes: L - local, C - connected, S - static, R - RIP, M - mobile, B - BGP D - EIGRP, EX - EIGRP external, O - OSPF, IA - OSPF inter area N1 - OSPF NSSA external type 1, N2 - OSPF NSSA external type 2 E1 - OSPF external type 1, E2 - OSPF external type 2 i - IS-IS, su - IS-IS summary, L1 - IS-IS level-1, L2 - IS-IS level-2 ia - IS-IS inter area, * - candidate default, U - per-user static route o - ODR, P - periodic downloaded static route, H - NHRP, I - LISP a - application route + - replicated route, % - next hop override

```

Gateway of last resort is not set
172.16.0.0/16 is variably subnetted, 6 subnets, 2 masks
  C 172.16.12.0/29 is directly connected, Serial1/0
  L 172.16.12.1/32 is directly connected, Serial1/0
  C 172.16.13.0/29 is directly connected, Serial1/1
  L 172.16.13.1/32 is directly connected, Serial1/1
  D 172.16.23.0/29 [90/2681856] via 172.16.13.3, 00:08:31, Serial1/1 [90/2681856] via
172.16.12.2, 00:08:31, Serial1/0
  D 172.16.34.0/29 [90/2681856] via 172.16.13.3, 00:08:31, Serial1/1 192.168.1.0/24 is
variably subnetted, 2 subnets, 2 masks
  C 192.168.1.0/24 is directly connected, Loopback1
  L 192.168.1.1/32 is directly connected, Loopback1
  D 192.168.2.0/24 [90/2297856] via 172.16.12.2, 00:08:31, Serial1/0
  D 192.168.3.0/24 [90/2297856] via 172.16.13.3, 00:08:31, Serial1/1 192.168.4.0/25 is
subnetted, 2 subnets
  D 192.168.4.0 [90/2809856] via 172.16.13.3, 00:05:15, Serial1/1
  D 192.168.4.128 [90/2809856] via 172.16.13.3, 00:05:15, Serial1/1
R2 Router>enable
Router#conf t
Router(config)#hostname R2
R2(config)#interface Lo2
R2(config-if)#ip address 192.168.2.1 255.255.255.0
R2(config-if)#exit
R2(config)#interface s1/0
R2(config-if)#ip address 172.16.12.2 255.255.255.248
R2(config-if)#no shutdown
R2(config-if)#exit
R2(config)#interface s1/1
R2(config-if)#ip address 172.16.23.2 255.255.255.248
R2(config-if)#no shutdown R2(config-if)#exit
R2(config)#router eigrp 100
R2(config-router)#network 192.168.2.0
R2(config-router)#network 172.16.12.0
R2(config-router)#network 172.16.23.0
R2(config-router)#no auto-summary
R2#sh ip eigrp neighbors EIGRP-IPv4
Neighbors for AS(100) H Address Interface Hold Uptime SRTT RTO Q Seq (sec) (ms) Cnt Num
1 172.16.23.3 Se1/1 12 00:05:23 12 100 0 11 0 172.16.12.1 Se1/0 12 00:07:45 22 132 0 8 R3
Router>enable
Router#conf t
Router(config)#hostname R3
R3(config)#interface Lo3
R3(config-if)#ip address 192.168.3.1 255.255.255.0
R3(config-if)#exit
R3(config)#interface s1/0
R3(config-if)#ip address 172.16.13.3 255.255.255.248
R3(config-if)#no shutdown

```

```

R3(config-if)#exit
R3(config)#interface s1/1
R3(config-if)#ip address 172.16.23.3 255.255.255.248
R3(config-if)#no shutdown
R3(config-if)#exit
R3(config)#interface s1/2
R3(config-if)#ip address 172.16.34.3 255.255.255.248
R3(config-if)#no shutdown
R3(config-if)#exit
R3(config)#router eigrp 100
R3(config-router)#network 192.168.3.0
R3(config-router)#network 172.16.13.0
R3(config-router)#network 172.16.23.0
R3(config-router)#network 172.16.34.0
R3(config-router)#no auto-summary
R3#sh ip eigrp neighbors EIGRP-IPv4 Neighbors for AS(100) H Address Interface Hold
Uptime SRTT RTO Q Seq (sec) (ms) Cnt Num 2 172.16.34.4 Se1/2 14 00:03:09 15 100 0 3 1
172.16.13.1 Se1/0 14 00:06:25 21 126 0 9 0 172.16.23.2 Se1/1 13 00:06:25 20 120 0 9
R3#sh ip route
Codes: L - local, C - connected, S - static, R - RIP, M - mobile, B - BGP D - EIGRP, EX - EIGRP
external, O - OSPF, IA - OSPF inter area N1 - OSPF NSSA external type 1, N2 - OSPF NSSA
external type 2 E1 - OSPF external type 1, E2 - OSPF external type 2 i - IS-IS, su - IS-IS
summary, L1 - IS-IS level-1, L2 - IS-IS level-2 ia - IS-IS inter area, * - candidate default, U - per-
user static route o - ODR, P - periodic downloaded static route, H - NHRP, I - LISP a -
application route + - replicated route, % - next hop override
Gateway of last resort is not set
172.16.0.0/16 is variably subnetted, 7 subnets, 2 masks
D 172.16.12.0/29 [90/2681856] via 172.16.23.2, 00:16:48, Serial1/1 [90/2681856] via
172.16.13.1, 00:16:48, Serial1/0
C 172.16.13.0/29 is directly connected, Serial1/0
L 172.16.13.3/32 is directly connected, Serial1/0
C 172.16.23.0/29 is directly connected, Serial1/1
L 172.16.23.3/32 is directly connected, Serial1/1
C 172.16.34.0/29 is directly connected, Serial1/2
L 172.16.34.3/32 is directly connected, Serial1/2
D 192.168.1.0/24 [90/2297856] via 172.16.13.1, 00:16:48, Serial1/0
D 192.168.2.0/24 [90/2297856] via 172.16.23.2, 00:16:48, Serial1/1 192.168.3.0/24 is
variably subnetted, 2 subnets, 2 masks
C 192.168.3.0/24 is directly connected, Loopback3
L 192.168.3.1/32 is directly connected, Loopback3 192.168.4.0/25 is subnetted, 2 subnets D
192.168.4.0 [90/2297856] via 172.16.34.4, 00:13:32, Serial1/2
D 192.168.4.128 [90/2297856] via 172.16.34.4, 00:13:32, Serial1/2
R3(config)#ip access-list standard PBR-ACL
R3(config-std-nacl)#remark ACL matches
R4 LAN B traffic
R3(config-std-nacl)#permit 192.168.4.128 0.0.0.127
R3(config-std-nacl)#exit

```

```
R3(config)#route-map R3-to-R1 permit
R3(config-route-map)#match ip address PBR-ACL
R3(config-route-map)#set ip next-hop 172.16.13.1
R3(config-route-map)#end
R3(config)#int s1/2
R3(config-if)#ip policy route-map R3-to-R1
R3(config-if)#exit
R3#sh route-map route-map R3-to-R1, permit, sequence 10 Match clauses: ip address
(access-lists): PBR-ACL Set clauses: ip next-hop 172.16.13.1 Policy routing matches: 0
packets, 0 bytes R3(config)#access-list 1 permit 192.168.4.0 0.0.0.255
R4
Router>enable
Router#conf t
Router(config)#hostname R4
R4(config)#interface lo4
R4(config-if)#ip address 192.168.4.1 255.255.255.128
R4(config-if)#exit
R4(config)#interface lo5
R4(config-if)#ip address 192.168.4.129 255.255.255.128
R4(config-if)#exit
R4(config)#interface s1/0
R4(config-if)#ip address 172.16.34.4 255.255.255.248
R4(config-if)#no shutdown
R4(config-if)#exit
R4(config)#router eigrp 100
R4(config-router)#network 192.168.4.0
R4(config-router)#network 172.16.34.0
R4(config-router)#no auto-summary
R4#sh ip eigrp neighbors EIGRP-IPv4 Neighbors for AS(100) H Address Interface Hold Uptime
SRTT RTO Q Seq (sec) (ms) Cnt Num 0 172.16.34.3 Se1/0 14 00:04:07 25 150 0 9 Before
Route Maps R4#traceroute 192.168.1.1 source 192.168.4.1
Type escape sequence to abort.
Tracing the route to 192.168.1.1
VRF info: (vrf in name/id, vrf out name/id) 1 172.16.34.3 13 msec 11 msec 10 msec 2
172.16.13.1 20 msec 17 msec *
R4#traceroute 192.168.1.1 source 192.168.4.129
Type escape sequence to abort.
Tracing the route to 192.168.1.1
VRF info: (vrf in name/id, vrf out name/id) 1 172.16.34.3 15 msec 10 msec 10 msec 2
172.16.13.1 19 msec 24 msec *
After Route Maps R4#traceroute 192.168.1.1 source 192.168.4.1
Type escape sequence to abort. Tracing the route to 192.168.1.1
VRF info: (vrf in name/id, vrf out name/id) 1 172.16.34.3 11 msec 10 msec 10 msec 2
172.16.13.1 21 msec 22 msec *
R4#traceroute 192.168.1.1 source 192.168.4.129
Type escape sequence to abort.
Tracing the route to 192.168.1.1
```

VRF info: (vrf in name/id, vrf out name/id) 1 172.16.34.3 10 msec 10 msec 10 msec 2
172.16.13.1 18 msec 18 msec

Practical 6

NETWORK TOPOLOGY

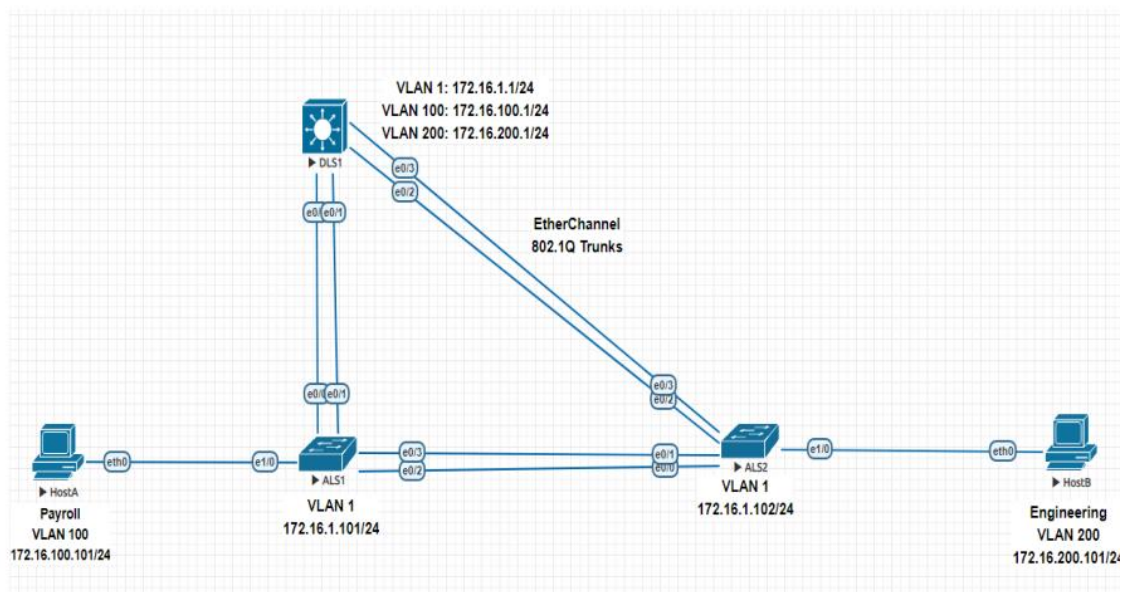

```
DLS1 Switch>en
Switch#conf t
Switch(config)#hostname DLS1
DLS1(config)#interface vlan 1
DLS1(config-if)#ip address 172.16.1.1 255.255.255.0
DLS1(config-if)#no shutdown
DLS1(config-if)#exit Configure the trunks and EtherChannel from DLS1 to ALS1.
DLS1(config)#interface range e0/0-1
DLS1(config-if-range)#switchport trunk encapsulation dot1q
DLS1(config-if-range)#switchport mode trunk
DLS1(config-if-range)#channel-group 1 mode desirable Creating a port-channel interface
Port-channel 1
DLS1(config-if-range)#exit Configure the trunks and EtherChannel from DLS1 to ALS2.
DLS1(config)#interface range e0/2-3
DLS1(config-if-range)#switchport trunk encapsulation dot1q
```

```

DLS1(config-if-range)#switchport mode trunk
DLS1(config-if-range)#channel-group 2 mode desirable Creating a port-channel interface
Port-channel 2
DLS1(config-if-range)#exit Configure VTP on DLS1 and create VLANs 100 and 200 for the
domain DLS1(config)#vtp domain SWPOD Changing VTP domain name from NULL to SWPOD
DLS1(config)#vtp version 2
DLS1(config)#vlan 100
DLS1(config-vlan)#name Payroll
DLS1(config-vlan)#exit
DLS1(config)#vlan 200
DLS1(config-vlan)#name Engineering
DLS1(config-vlan)#exit On DLS1, create the SVIs for VLANs 100 and 200.
Note that the corresponding Layer 2 VLANs must be configured for the Layer 3 SVIs to
activate DLS1(config)#interface vlan 100
DLS1(config-if)#ip address 172.16.100.1 255.255.255.0
DLS1(config-if)#no shutdown
DLS1(config-if)#exit
DLS1(config)#interface vlan 200
DLS1(config-if)#ip address 172.16.200.1 255.255.255.0
DLS1(config-if)#no shutdown
DLS1(config-if)#exit The ip routing command is also needed to allow the
DLS1 switch to act as a Layer 3 device to route between these VLANs. Because the VLANs
are all considered directly connected, a routing protocol is not needed at this time. The
default configuration on 3560 switches is no ip routing.
DLS1(config)#ip routing
DLS1#sh ip route Codes: L - local, C - connected, S - static, R - RIP, M - mobile, B - BGP D -
EIGRP, EX - EIGRP external, O - OSPF, IA - OSPF inter area N1 - OSPF NSSA external type 1, N2
- OSPF NSSA external type 2 E1 - OSPF external type 1, E2 - OSPF external type 2 i - IS-IS, su
- IS-IS summary, L1 - IS-IS level-1, L2 - IS-IS level-2 ia - IS-IS inter area, * - candidate default, U -
per-user static route o - ODR, P - periodic downloaded static route, H - NHRP, I - LISP a -
application route + - replicated route, % - next hop override
Gateway of last resort is not set
172.16.0.0/16 is variably subnetted, 6 subnets, 2 masks
C 172.16.1.0/24 is directly connected, Vlan1
L 172.16.1.1/32 is directly connected, Vlan1
C 172.16.100.0/24 is directly connected, Vlan100
L 172.16.100.1/32 is directly connected, Vlan100
C 172.16.200.0/24 is directly connected, Vlan200
L 172.16.200.1/32 is directly connected, Vlan200
Configure the Cisco IOS IP SLA source to measure network performance
DLS1(config)#ip sla 1
DLS1(config-ip-sla)#icmp-echo 172.16.100.101
DLS1(config-ip-sla-echo)#exit
DLS1(config)#ip sla 2
DLS1(config-ip-sla)#icmp-echo 172.16.200.101
DLS1(config-ip-sla-echo)#exit
DLS1(config)#ip sla 3

```

```
DLS1(config-ip-sla)#udp-jitter 172.16.1.101 5000
DLS1(config-ip-sla-jitter)#exit
DLS1(config)#ip sla 4
DLS1(config-ip-sla)#udp-jitter 172.16.1.102 5000
DLS1(config-ip-sla-jitter)#exit
DLS1(config)#ip sla schedule 1 life forever start-time now
DLS1(config)#ip sla schedule 2 life forever start-time now
DLS1(config)#ip sla schedule 3 life forever start-time now
DLS1(config)#ip sla schedule 4 life forever start-time now Monitor IP SLAs operations
DLS1#show ip sla configuration 1
IP SLAs Infrastructure Engine-III Entry number: 1 Owner: Tag: Operation timeout
(milliseconds): 5000 Type of operation to perform: icmp-echo Target address/Source
address: 172.16.100.101/0.0.0.0 Type Of Service parameter: 0x0 Request size (ARR data
portion): 28 Data pattern: 0xABCDABCD Verify data: No Vrf Name: Schedule: Operation
frequency (seconds): 60 (not considered if randomly scheduled)
Next Scheduled Start Time: Start Time already passed Group Scheduled : FALSE Randomly
Scheduled : FALSE Life (seconds): Forever Entry Ageout (seconds): never
Recurring (Starting Everyday): FALSE Status of entry (SNMP RowStatus): Active Threshold
(milliseconds): 5000
Distribution Statistics:
Number of statistic hours kept: 2
Number of statistic distribution buckets kept: 1
Statistic distribution interval (milliseconds): 20 Enhanced History: History Statistics:
Number of history Lives kept: 0
Number of history Buckets kept: 15
History Filter Type: None
DLS1#show ip sla configuration 3 IP SLAs Infrastructure Engine-III
Entry number: 3
Owner: Tag: Operation timeout (milliseconds): 5000
Type of operation to perform: udp-jitter
Target address/Source address: 172.16.1.101/0.0.0.0 Target port/Source port: 5000/0
Type Of Service parameter: 0x0
Request size (ARR data portion): 32
Packet Interval (milliseconds)/Number of packets: 20/10 Verify data:
No Vrf Name: Control Packets: enabled Schedule:
Operation frequency (seconds): 60 (not considered if randomly scheduled)
Next Scheduled Start Time: Start Time already passed Group Scheduled : FALSE Randomly
Scheduled : FALSE Life (seconds): Forever Entry Ageout (seconds): never
Recurring (Starting Everyday): FALSE Status of entry (SNMP RowStatus): Active Threshold
(milliseconds): 5000 Distribution Statistics:
Number of statistic hours kept: 2
Number of statistic distribution buckets kept: 1 Statistic distribution interval (milliseconds):
20 Enhanced History: Percentile:
DLS1#show ip sla application IP Service Level Agreements Version: Round Trip Time MIB
2.2.0, Infrastructure Engine-III
```

Supported Operation Types: icmpEcho, path-echo, path-jitter, udpEcho, tcpConnect, http dns, udpJitter, dhcp, ftp, lsp Group, lspPing, lspTrace pseudowirePing, udpApp, wspApp, mcast, generic Supported Features: IPSLAs Event Publisher IP SLAs low memory water mark: 225778552 Estimated system max number of entries: 165365
Estimated number of configurable operations: 165241 Number of Entries configured : 4
Number of active Entries : 4
Number of pending Entries : 0
Number of inactive Entries : 0 Time of last change in whole IP SLAs: *14:08:46.139 EET Sat Apr 11 2020
DLS1#show ip sla statistics 1 IPSLAs
Latest Operation Statistics IPSLA operation id: 1 Latest RTT: 1 milliseconds Latest operation start time: 14:34:23 EET Sat Apr 11 2020
Latest operation return code: OK
Number of successes: 26
Number of failures: 1 Operation time to live: Forever
DLS1#show ip sla statistics 3 IPSLAs Latest Operation Statistics IPSLA operation id: 3 Type of operation: udp-jitter Latest RTT: 1 milliseconds Latest operation start time: 14:34:36 EET Sat Apr 11 2020 Latest operation return code: OK RTT Values: Number Of RTT: 10 RTT Min/Avg/Max: 1/1/2 milliseconds Latency one-way time : Number of Latency one-way Samples: 6
Source to Destination Latency one way Min/Avg/Max: 0/0/1 milliseconds Destination to Source Latency one way Min/Avg/Max: 0/0/1 milliseconds Jitter Time: Number of SD Jitter Samples: 9
Number of DS Jitter Samples: 9
Source to Destination Jitter Min/Avg/Max: 0/1/1 milliseconds
Destination to Source Jitter Min/Avg/Max: 0/1/1 milliseconds Over Threshold: Number Of RTT Over Threshold: 0 (0%) Packet Loss Values: Loss Source to Destination: 0
Source to Destination Loss Periods Number: 0 Source to Destination Loss Period Length Min/Max: 0/0
Source to Destination Inter Loss Period Length Min/Max: 0/0 Loss Destination to Source: 0
Destination to Source Loss Periods Number: 0
Destination to Source Loss Period Length Min/Max: 0/0
Destination to Source Inter Loss Period Length Min/Max: 0/0 Out Of Sequence: 0 Tail Drop: 0
Packet Late Arrival: 0 Packet Skipped: 0 Voice Score Values: Calculated Planning Impairment Factor (ICPIF): 0 Mean Opinion Score (MOS): 0
Number of successes: 27
Number of failures: 0 Operation time to live: Forever
Configure Remote Span
DLS1(config)#vlan 100 DLS1(config-vlan)#remote-span
DLS1(config-vlan)#exit
t DLS1(config)#monitor session 1 source interface e0/0 both
DLS1(config)# monitor session 1 destination remote vlan 100 ALS1
Switch>en Switch#conf t
Switch(config)#hostname ALS1
ALS1(config)#interface vlan 1
ALS1(config-if)#ip address 172.16.1.101 255.255.255.0
ALS1(config-if)#no shutdown
ALS1(config-if)#exit
ALS1(config)#ip default-gateway 172.16.1.1
Configure the trunks and EtherChannel between ALS1 and DLS1
ALS1(config)#interface range e0/0-1

```
ALS1(config-if-range)# switchport trunk encapsulation dot1q
ALS1(config-if-range)#switchport mode trunk
ALS1(config-if-range)#channel-group 1 mode desirable Creating a port-channel interface
Port-channel 1
ALS1(config-if-range)#exit
Configure the trunks and EtherChannel between ALS1 and ALS2
ALS1(config)#interface range e0/2-3
ALS1(config-if-range)#switchport trunk encapsulation dot1q
ALS1(config-if-range)#switchport mode trunk
ALS1(config-if-range)#channel-group 2 mode desirable Creating a port-channel interface
Port-channel 2 Configure VTP on ALS1
ALS1(config)#vtp mode client Setting device to VTP Client mode for VLANS.
ALS1(config)#int e1/0
ALS1(config-if)#switchport mode access
ALS1(config-if)#switchport access vlan 100
ALS1(config-if)#exit Configure Cisco IOS IP SLA responders.
ALS1(config)#ip sla responder
ALS1(config)#ip sla responder udp-echo ipaddress 172.16.1.1 port 5000
ALS1#show ip sla responder General IP SLA Responder on Control port 1967
General IP SLA Responder on Control V2 port 1167 General IP SLA Responder is: Enabled
Number of control message received: 16
Number of errors: 0 Recent sources: 172.16.1.1 [14:23:36.259 EET Sat Apr 11 2020]
172.16.1.1 [14:22:36.257 EET Sat Apr 11 2020] 172.16.1.1 [14:21:36.255 EET Sat Apr 11
2020] 172.16.1.1 [14:20:36.256 EET Sat Apr 11 2020] 172.16.1.1 [14:19:36.258 EET Sat Apr
11 2020] Recent error sources:
Number of control v2 message received: 0
Number of errors: 0
Recent sources: Recent error sources:
Permanent Port IP SLA Responder Permanent Port IP SLA Responder is: Enabled udpEcho
Responder: IP Address Port 172.16.1.1 5000
ALS2 Switch>en Switch#conf t Enter configuration commands, one per line. End with
CNTL/Z. Switch(config)#hostname ALS2
ALS2(config)#interface vlan 1
ALS2(config-if)#ip address 172.16.1.102 255.255.255.0
ALS2(config-if)#no shutdown
ALS2(config-if)#exit
ALS2(config)#ip default-gateway 172.16.1.1 Configure the trunks and EtherChannel between
ALS2 and ALS1
ALS2(config)#interface range e0/0-1
ALS2(config-if-range)#switchport trunk encapsulation dot1q
ALS2(config-if-range)#switchport mode trunk
ALS2(config-if-range)#channel-group 2 mode desirable Creating a port-channel interface
Port-channel 2
ALS2(config-if-range)#exit Configure the trunks and EtherChannel between ALS2 and DLS1
ALS2(config)#interface range e0/2-3
ALS2(config-if-range)#switchport trunk encapsulation dot1q
ALS2(config-if-range)#switchport mode trunk
```

```

ALS2(config-if-range)#channel-group 1 mode desirable Creating a port-channel interface
Port-channel 1
ALS2(config-if-range)#exit Configure VTP on ALS2
ALS2(config)#vtp mode
client Setting device to VTP Client mode for VLANS
ALS2(config)#int e1/0 ALS2(config-if)#switchport mode access
ALS2(config-if)#switchport access vlan 200
ALS2(config-if)#exit Configure Cisco IOS IP SLA responders.
ALS2(config)#ip sla responder
ALS2(config)#ip sla responder udp-echo ipaddress 172.16.1.1 port 5000

```

Practical 7

NETWORK TOPOLOGY

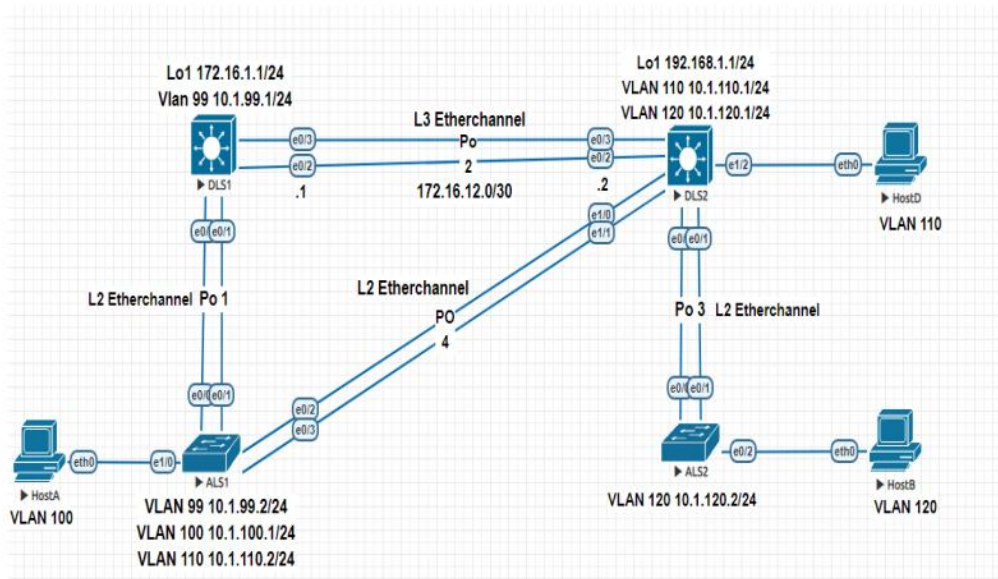

```

DLS1 Switch>enable
Switch#conf t
Switch(config)#hostname DLS1
DLS1(config)#interface loopback 1
DLS1(config-if)#ip address 172.16.1.1 255.255.255.0
DLS1(config-if)#exit
DLS1(config)#interface vlan 99
DLS1(config-if)#ip address 10.1.99.1 255.255.255.0
DLS1(config-if)#no shutdown
Implement a Layer 3 EtherChannel
DLS1(config)#int range e0/2-3
DLS1(config-if-range)#no switchport

```

```

DLS1(config-if-range)#no ip address
DLS1(config-if-range)#channel-group 2 mode on Creating a port-channel interface Port-
channel 2 DLS1(config-if-range)#exit
DLS1(config)#interface port-channel 2
DLS1(config-if)#ip address 172.16.12.1 255.255.255.252
DLS1(config-if)#end
DLS1(config)#int range e0/0-1
DLS1(config-if-range)#switchport trunk encapsulation dot1q
DLS1(config-if-range)#switchport mode trunk
DLS1(config-if-range)#channel-group 1 mode desirable Creating a port-channel interface
Port-channel 1
DLS1(config-if-range)#end
DLS1#sh interfaces trunk Port Mode Encapsulation Status Native vlan Po1 on 802.1q
trunking 1 Port Vlans allowed on trunk Po1 1-4094 Port Vlans allowed and active in
management domain Po1 1,99 Port Vlans in spanning tree forwarding state and not pruned
Po1 1,99 Implement Static Routing DLS1(config)#ip routing
DLS1(config)#ip route 192.168.1.0 255.255.255.252 172.16.12.2
DLS1(config)# ip route 192.168.1.0 255.255.255.0 10.1.120.1
DLS1(config)# ip route 192.168.1.0 255.255.255.0 10.1.110.1
DLS1#sh ip route Codes: L - local, C - connected, S - static, R - RIP, M - mobile, B - BGP D -
EIGRP, EX - EIGRP external, O - OSPF, IA - OSPF inter area N1 - OSPF NSSA external type 1, N2
- OSPF NSSA external type 2 E1 - OSPF external type 1, E2 - OSPF external type 2 i - IS-IS, su
- IS-IS summary, L1 - IS-IS level-1, L2 - IS-IS level-2 ia - IS-IS inter area, * - candidate default, U -
per-user static route o - ODR, P - periodic downloaded static route, H - NHRP, I - LISP a -
application route + - replicated route, % - next hop override
Gateway of last resort is not set 10.0.0.0/8 is variably subnetted, 2 subnets, 2 masks
C 10.1.99.0/24 is directly connected, Vlan99
L 10.1.99.1/32 is directly connected, Vlan99 172.16.0.0/16 is variably subnetted, 4 subnets,
3 masks C 172.16.1.0/24 is directly connected, Loopback1
L 172.16.1.1/32 is directly connected, Loopback1
C 172.16.12.0/30 is directly connected, Port-channel2
L 172.16.12.1/32 is directly connected, Port-channel2 192.168.1.0/30 is subnetted, 1
subnets S 192.168.1.0 [1/0] via 172.16.12.2
DLS2 Switch>en Switch#conf t
Switch(config)#hostname DLS2
DLS2(config)#interface loopback 1
DLS2(config-if)#ip address 192.168.1.1 255.255.255.0
DLS2(config-if)#exit
DLS2(config)#interface vlan 110
DLS2(config-if)#ip address 10.1.110.1 255.255.255.0
DLS2(config-if)#no shutdown
DLS2(config-if)#exi
t DLS2(config)#interface vlan 120
DLS2(config-if)#ip address 10.1.120.1 255.255.255.0
DLS2(config-if)#no shutdown
DLS2(config-if)#exit Implement a Layer 3 EtherChannel
DLS2(config)#interface range e0/2-3

```

```

DLS2(config-if-range)#no switchport
DLS2(config-if-range)#no ip
DLS2(config-if-range)#no ip address
DLS2(config-if-range)#channel-group 2 mode on Creating a port-channel interface Port-
channel 2 DLS2(config-if-range)#exit
DLS2(config)#interface port-channel 2
DLS2(config-if)#ip address 172.16.12.2 255.255.255.252
DLS2(config-if)#end DLS2(config)#interface range e0/0-1
DLS2(config-if-range)#switchport trunk encapsulation dot1q
DLS2(config-if-range)#switchport mode trunk
DLS2(config-if-range)#channel-group 3 mode desirable Creating a port-channel interface
Port-channel 3
DLS2(config-if-range)#exit
DLS2(config)#interface range e1/0-1
DLS2(config-if-range)#switchport trunk encapsulation dot1q
DLS2(config-if-range)#switchport mode trunk
DLS2(config-if-range)#channel-group 4 mode desirable Creating a port-channel interface
Port-channel 4
DLS2(config-if-range)#end
DLS2#sh interfaces trunk Port Mode Encapsulation Status Native vlan Po3 on 802.1q
trunking 1 Po4 on 802.1q trunking 1 Port Vlans allowed on trunk Po3 1-4094 Po4 1-4094
Port Vlans allowed and active in management domain Po3 1,110,120 Po4 1,110,120 Port
Vlans in spanning tree forwarding state and not pruned Po3 1,110,120 Po4 1,110,120
Implement Static Routing DLS2(config)#ip routing DLS2(config)#ip route 172.16.1.0
255.255.255.252 172.16.12.1
DLS2(config)# ip route 172.16.1.0 255.255.255.0 10.1.99.1 Configure the host ports for the
appropriate VLANs according to the diagram
DLS2(config)#interface e1/2
DLS2(config-if)#switchport mode access
DLS2(config-if)#switchport access vlan 110
DLS2#sh ip route
Codes: L - local, C - connected, S - static, R - RIP, M - mobile, B - BGP D - EIGRP, EX - EIGRP
external, O - OSPF, IA - OSPF inter area N1 - OSPF NSSA external type 1, N2 - OSPF NSSA
external type 2 E1 - OSPF external type 1, E2 - OSPF external type 2 i - IS-IS, su - IS-IS
summary, L1 - IS-IS level-1, L2 - IS-IS level-2 ia - IS-IS inter area, * - candidate default, U - per-
user static route o - ODR, P - periodic downloaded static route, H - NHRP, I - LISP a -
application route + - replicated route, % - next hop override
Gateway of last resort is not set 10.0.0.0/8 is variably subnetted, 4 subnets, 2 masks
C 10.1.110.0/24 is directly connected, Vlan110
L 10.1.110.1/32 is directly connected, Vlan110
C 10.1.120.0/24 is directly connected, Vlan120
L 10.1.120.1/32 is directly connected, Vlan120 172.16.0.0/16 is variably subnetted, 3
subnets, 2 masks S 172.16.1.0/30 [1/0] via 172.16.12.1
C 172.16.12.0/30 is directly connected, Port-channel2
L 172.16.12.2/32 is directly connected, Port-channel2 192.168.1.0/24 is variably subnetted,
2 subnets, 2 masks
C 192.168.1.0/24 is directly connected, Loopback1

```

```

L 192.168.1.1/32 is directly connected, Loopback1 ALS1
Switch>en Switch#conf t S
Switch(config)#hostname ALS1
ALS1(config)#ip default-gateway 10.1.99.1
ALS1(config)#ip default-gateway 10.1.110.1
ALS1(config)#ip default-gateway 10.1.100.2 Implement a Layer 3 EtherChannel
ALS1(config)#int range e0/0-1
ALS1(config-if-range)#switchport trunk encapsulation dot1q
ALS1(config-if-range)#switchport mode trunk
ALS1(config-if-range)#channel-group 1 mode desirable Creating a port-channel interface
Port-channel 1
ALS1(config-if-range)#exit
ALS1(config)#int range e0/2-3
ALS1(config-if-range)#switchport trunk encapsulation dot1q
ALS1(config-if-range)#switchport mode trunk
ALS1(config-if-range)#channel-group 4 mode desirable Creating a port-channel interface
Port-channel 4
ALS1(config-if-range)#end
ALS1#sh etherchannel summary
Flags: D - down P - bundled in port-channel I - stand-alone s - suspended H - Hot-standby
(LACP only) R - Layer3 S - Layer2 U - in use N - not in use, no aggregation f - failed to allocate
aggregator M - not in use, minimum links not met m - not in use, port not aggregated due to
minimum links not met u - unsuitable for bundling w - waiting to be aggregated d - default
port A - formed by Auto LAG Number of channel-groups in use: 2
Number of aggregators: 2
Group Port-channel Protocol Ports -----+-----+-----+-----
----- 1 Po1(SU) PAgP Et0/0(P) Et0/1(P) 4 Po4(SU) PAgP Et0/2(P) Et0/3(P)
Configure the host ports for the appropriate VLANs according to the diagram
ALS1(config)#interface e1/0
ALS1(config-if)#switchport mode access
ALS1(config-if)#switchport access vlan 100 ALS2
Switch>en Switch#conf t
Switch(config)#hostname ALS2
ALS2(config)#ip default-gateway 10.1.120.1 Implement a Layer 3 EtherChannel
ALS2(config)#int range e0/0-1
ALS2(config-if-range)#switchport trunk encapsulation dot1q
ALS2(config-if-range)#switchport mode trunk
ALS2(config-if-range)#channel-group 3 mode desirable Creating a port-channel interface
Port-channel 3
ALS2(config-if-range)#end
ALS2#sh etherchannel summary
Flags: D - down P - bundled in port-channel I - stand-alone s - suspended H - Hot-standby
(LACP only) R - Layer3 S - Layer2 U - in use N - not in use, no aggregation f - failed to allocate
aggregator M - not in use, minimum links not met m - not in use, port not aggregated due to
minimum links not met u - unsuitable for bundling w - waiting to be aggregated d - default
port A - formed by Auto LAG Number of channel-groups in use: 1
Number of aggregators: 1

```

Group Port-channel Protocol Ports -----+-----+-----+-----
----- 3 Po3(SU) PAgP Et0/0(P) Et0/1(P) Configure the host ports for the appropriate VLANs
according to the diagram
ALS2(config)#interface e0/2
ALS2(config-if)#switchport mode access
ALS2(config-if)#switchport access vlan 120 HOST A VPCS> ip 10.1.100.1 255.255.255.0
10.1.100.2 HOST B
VPCS> ip 10.1.120.2 255.255.255.0 10.1.120.1 HOST D
VPCS> ip 10.1.110.2 255.255.255.0 10.1.110.1

Practical 8

NETWORK TOPOLOGY

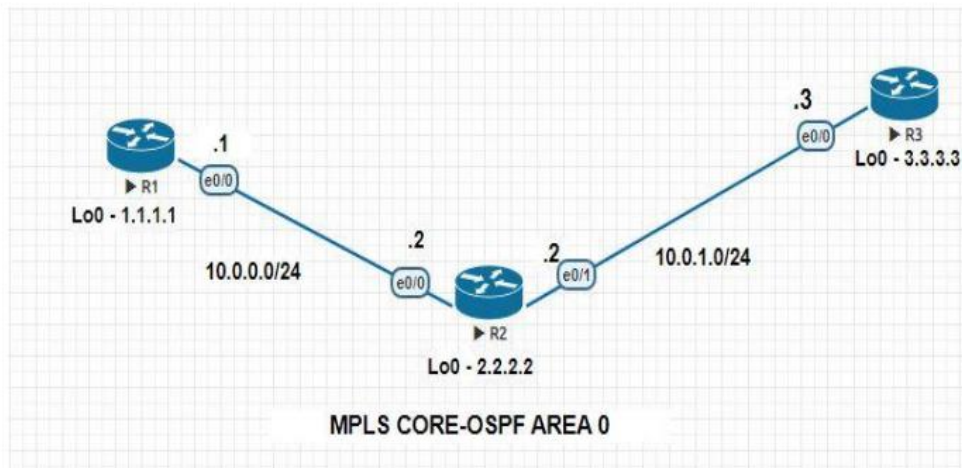

```
R1 Router>enable
Router#conf t
Router(config)#hostname R1
R1(config)# interface loopback 0
R1(config-if)#ip address 1.1.1.1 255.255.255.255
R1(config-if)#exit R1(config)#int e0/0
R1(config-if)#ip address 10.0.0.1 255.255.255.0
R1(config-if)#no shut
R1(config)#router ospf 1
R1(config-router)#network 1.1.1.0 0.0.0.255 area 0
R1(config-router)#network 10.0.0.0 0.0.0.255 area 0
R1(config-router)#exit R
1#show ip route ospf
Codes: L - local, C - connected, S - static, R - RIP, M - mobile, B - BGP D - EIGRP, EX - EIGRP
external, O - OSPF, IA - OSPF inter area N1 - OSPF NSSA external type 1, N2 - OSPF NSSA
external type 2 E1 - OSPF external type 1, E2 - OSPF external type 2 i - IS-IS, su - IS-IS
summary, L1 - IS-IS level-1, L2 - IS-IS level-2 ia - IS-IS inter area, * - candidate default, U - per-
user static route o - ODR, P - periodic downloaded static route, H - NHRP, I - LISP a -
application route + - replicated route, % - next hop override
Gateway of last resort is not set
2.0.0.0/32 is subnetted, 1 subnets O 2.2.2.2 [110/11] via 10.0.0.2, 00:15:40, Ethernet0/0
3.0.0.0/32 is subnetted, 1 subnets
O 3.3.3.3 [110/21] via 10.0.0.2, 00:04:01, Ethernet0/0 10.0.0.0/8 is variably subnetted, 3
subnets, 2 masks
O 10.0.1.0/24 [110/20] via 10.0.0.2, 00:09:25, Ethernet0/0
R1#sh ip cef Prefix Next Hop Interface 0.0.0.0/0 no route 0.0.0.0/8 drop 0.0.0.0/32
receive 1.1.1.1/32 receive Loopback0 2.2.2.2/32 10.0.0.2
Ethernet0/0 3.3.3.3/32 10.0.0.2 Ethernet0/0 10.0.0.0/24 attached Ethernet0/0 10.0.0.0/32
receive Ethernet0/0 10.0.0.1/32 receive Ethernet0/0 10.0.0.2/32 attached Ethernet0/0
10.0.0.255/32 receive Ethernet0/0 10.0.1.0/24 10.0.0.2
Ethernet0/0 127.0.0.0/8 drop 224.0.0.0/4 drop 224.0.0.0/24 receive 240.0.0.0/4 drop
255.255.255.255/32 receive
R1#sh ip route 2.2.2.2
```

```
Routing entry for 2.2.2.2/32 Known via "ospf 1", distance 110, metric 11, type intra area
Last update from 10.0.0.2 on Ethernet0/0, 00:30:34 ago Routing Descriptor Blocks: *
10.0.0.2, from 2.2.2.2, 00:30:34 ago, via Ethernet0/0 Route metric is 11, traffic share count
is 1 R1#sh ip route 3.3.3.3 Routing entry for 3.3.3.3/32 Known via "ospf 1", distance 110,
metric 21, type intra area Last update from 10.0.0.2 on Ethernet0/0, 00:11:43 ago Routing
Descriptor Blocks: * 10.0.0.2, from 3.3.3.3, 00:11:43 ago, via Ethernet0/0 Route metric is 21,
traffic share count is 1 R1#sh ip cef 2.2.2.2 2.2.2.2/32 nexthop 10.0.0.2 Ethernet0/0
R1#sh ip cef 3.3.3.3 3.3.3.3/32 nexthop 10.0.0.2 Ethernet0/0
R1(config)#mpls label range 100 199
R1(config)#mpls label protocol ldp
R1(config)#mpls ldp router-id loopback 0
R1(config)#int e0/0
R1(config-if)#mpls ip
R1#sh mpls interfaces Interface IP Tunnel BGP Static Operational Ethernet0/0 Yes (Ldp) No
No No Yes
R1#sh mpls ldp neighbor Peer LDP Ident: 2.2.2.2:0; Local LDP Ident 1.1.1.1:0 TCP connection:
2.2.2.2.27963 - 1.1.1.1.646 State: Oper; Msgs sent/rcvd: 13/14; Downstream Up time:
00:05:21 LDP discovery sources: Ethernet0/0, Src IP addr: 10.0.0.2 Addresses bound to peer
LDP Ident: 10.0.0.2 10.0.1.2 2.2.2.2
R1#sh ip cef 3.3.3.3 3.3.3.3/32 nexthop 10.0.0.2 Ethernet0/0 label 201
R1#sh ip cef 2.2.2.2 2.2.2.2/32 nexthop 10.0.0.2 Ethernet0/0
R1#sh mpls forwarding-table
Local Outgoing Prefix Bytes Label Outgoing Next Hop Label Label or Tunnel Id Switched
interface 100 Pop Label 2.2.2.2/32 0 Et0/0 10.0.0.2 101 201 3.3.3.3/32 0 Et0/0 10.0.0.2 102
Pop Label 10.0.1.0/24 0 Et0/0 10.0.0.2
R1#sh mpls ldp bindings lib entry: 1.1.1.1/32, rev 2
local binding: label: imp-null
remote binding: lsr: 2.2.2.2:0, label: 200
lib entry: 2.2.2.2/32, rev 4 local binding: label: 100 remote binding: lsr: 2.2.2.2:0, label: imp-
null
lib entry: 3.3.3.3/32, rev 6 local binding: label: 101 remote binding: lsr: 2.2.2.2:0, label: 201
lib entry: 10.0.0.0/24, rev 8 local binding: label: imp-null remote binding: lsr: 2.2.2.2:0, label:
imp-null lib entry: 10.0.1.0/24, rev 10 local binding: label: 102 remote binding: lsr: 2.2.2.2:0,
label: imp-null
R1#ping 3.3.3.3 source 10.0.0.1
Type escape sequence to abort. Sending 5, 100-byte
ICMP Echos to 3.3.3.3, timeout is 2 seconds:
Packet sent with a source address of 10.0.0.1 !!!!! Success rate is 100 percent (5/5), round-
trip min/avg/max = 1/1/2 ms
R1#traceroute 3.3.3.3 source 10.0.0.1 Type escape sequence to abort.
Tracing the route to 3.3.3.3 VRF info: (vrf in name/id, vrf out name/id) 1 10.0.0.2 [MPLS:
Label 201 Exp 0] 1 msec 1 msec 0 msec 2 10.0.1.3 1 msec 2 msec
* R1#ping 2.2.2.2 source 10.0.0.1 Type escape sequence to abort. Sending 5, 100-byte ICMP
Echos to 2.2.2.2, timeout is 2 seconds:
Packet sent with a source address of 10.0.0.1 !!!!!
Success rate is 100 percent (5/5), round-trip min/avg/max = 5/5/6 ms R1#traceroute 2.2.2.2
source 10.0.0.1 Type escape sequence to abort.
```

```

Tracing the route to 2.2.2.2 VRF info: (vrf in name/id, vrf out name/id) 1 10.0.0.2 2 msec 1
msec
* R2
Router>enable
Router#conf t
Router(config)#hostname R2
R2(config)# interface loopback 0
R2(config-if)#ip address 2.2.2.2 255.255.255.255
R2(config-if)# exit
R2(config)#int e0/0
R2(config-if)#ip address 10.0.0.2 255.255.255.0 R2(config-if)#no shut
R2(config)#int e0/1
R2(config-if)#ip address 10.0.1.2 255.255.255.0
R2(config-if)#no shut
R2(config)#router ospf 1
R2(config-router)#network 2.2.2.0 0.0.0.255 area 0
R2(config-router)#network 10.0.0.0 0.0.0.255 area 0 R2(config-router)#network 10.0.1.0
0.0.0.255 area 0
R2(config-router)#exit
R2#show ip route
  ospf Codes: L - local, C - connected, S - static, R - RIP, M - mobile, B - BGP D - EIGRP, EX -
EIGRP external, O - OSPF, IA - OSPF inter area N1 - OSPF NSSA external type 1, N2 - OSPF
NSSA external type 2 E1 - OSPF external type 1, E2 - OSPF external type 2 i - IS-IS, su - IS-IS
summary, L1 - IS-IS level-1, L2 - IS-IS level-2 ia - IS-IS inter area, * - candidate default, U - per-
user static route o - ODR, P - periodic downloaded static route, H - NHRP, I - LISP a -
application route + - replicated route, % - next hop override
  Gateway of last resort is not set
  1.0.0.0/32 is subnetted, 1 subnets O 1.1.1.1 [110/11] via 10.0.0.1, 00:15:32, Ethernet0/0
  3.0.0.0/32 is subnetted, 1 subnets O 3.3.3.3 [110/11] via 10.0.1.3, 00:03:58, Ethernet0/1
  R2#sh ip cef Prefix Next Hop Interface 0.0.0.0/0 no route 0.0.0.0/8 drop 0.0.0.0/32
  receive 1.1.1.1/32 10.0.0.1 Ethernet0/0 2.2.2.2/32
  receive Loopback0 3.3.3.3/32 10.0.1.3 Ethernet0/1 10.0.0.0/24 attached Ethernet0/0
  10.0.0.0/32
  receive Ethernet0/0 10.0.0.1/32 attached Ethernet0/0 10.0.0.2/32
  receive Ethernet0/0 10.0.0.255/32
  receive Ethernet0/0 10.0.1.0/24 attached Ethernet0/1 10.0.1.0/32
  receive Ethernet0/1 10.0.1.2/32
  receive Ethernet0/1 10.0.1.3/32 attached Ethernet0/1 10.0.1.255/32 r
  eceive Ethernet0/1 127.0.0.0/8 drop 224.0.0.0/4 drop 224.0.0.0/24
  receive 240.0.0.0/4 drop 255.255.255.255/32 receive
  R2#sh ip route 1.1.1.1
  Routing entry for 1.1.1.1/32 Known via "ospf 1", distance 110, metric 11, type intra area
  Last update from 10.0.0.1 on Ethernet0/0, 00:33:11 ago
  Routing Descriptor Blocks: * 10.0.0.1, from 1.1.1.1, 00:33:11 ago, via Ethernet0/0 Route
  metric is 11, traffic share count is 1
  R2#sh ip route 3.3.3.3

```

```
Routing entry for 3.3.3.3/32 Known via "ospf 1", distance 110, metric 11, type intra area Last
update from 10.0.1.3 on Ethernet0/1, 00:21:49 ago R
outing Descriptor Blocks: * 10.0.1.3, from 3.3.3.3, 00:21:49 ago, via Ethernet0/1 Route
metric is 11, traffic share count is 1
R2#sh ip cef 1.1.1.1 1.1.1.1/32 nexthop 10.0.0.1 Ethernet0/0 R2#sh ip cef 3.3.3.3 3.3.3.3/32
nexthop 10.0.1.3 Ethernet0/1
R2(config)#mpls label range 200 299
R2(config)#mpls label protocol ldp
R2(config)#mpls ldp router-id loopback 0
R2(config)#int e0/0
R2(config-if)#mpls ip
R2(config-if)#int e0/1
R2(config-if)#mpls ip
R2#sh mpls interfaces
Interface IP Tunnel BGP Static Operational Ethernet0/0 Yes (ldp) No No No Yes Ethernet0/1
Yes (ldp) No No No Yes
R2#sh mpls forwarding-table
Local Outgoing Prefix Bytes Label Outgoing Next Hop Label Label or Tunnel Id Switched
interface 200 Pop Label 1.1.1.1/32 0 Et0/0 10.0.0.1 201 Pop Label 3.3.3.3/32 1266 Et0/1
10.0.1.3
R2#sh mpls ldp neighbor
Peer LDP Ident: 1.1.1.1:0; Local LDP Ident 2.2.2.2:0 TCP connection: 1.1.1.1.646 -
2.2.2.2.27963 State: Oper; Msgs sent/rcvd: 41/42; Downstream Up time: 00:29:24 LDP
discovery sources: Ethernet0/0, Src IP addr: 10.0.0.1 Addresses bound to peer LDP Ident:
10.0.0.1 1.1.1.1 Peer LDP Ident: 3.3.3.3:0; Local LDP Ident 2.2.2.2:0 TCP connection:
3.3.3.3.44196 - 2.2.2.2.646 State: Oper; Msgs sent/rcvd: 38/38; Downstream Up time:
00:27:24 LDP discovery sources: Ethernet0/1, Src IP addr: 10.0.1.3 Addresses bound to peer
LDP Ident: 10.0.1.3 3.3.3.3
R2#sh mpls ldp bindings
lib entry: 1.1.1.1/32, rev 2 local binding: label: 200 remote binding: lsr: 1.1.1.1:0, label: imp-
null remote binding: lsr: 3.3.3.3:0, label: 300
lib entry: 2.2.2.2/32, rev 4 local binding: label: imp-null remote binding: lsr: 1.1.1.1:0, label:
100 remote binding: lsr: 3.3.3.3:0, label: 301
lib entry: 3.3.3.3/32, rev 6 local binding: label: 201 remote binding: lsr: 1.1.1.1:0, label: 101
remote binding: lsr: 3.3.3.3:0, label: imp-null
lib entry: 10.0.0.0/24, rev 8 local binding: label: imp-null remote binding: lsr: 1.1.1.1:0, label:
imp-null remote binding: lsr: 3.3.3.3:0, label: 302
lib entry: 10.0.1.0/24, rev 10 local binding: label: imp-null remote binding: lsr: 1.1.1.1:0,
label: 102 remote binding: lsr: 3.3.3.3:0, label: imp-null
R2#ping 1.1.1.1 source 10.0.0.2
Type escape sequence to abort. Sending 5, 100-byte ICMP Echos to 1.1.1.1, timeout is 2
seconds:
Packet sent with a source address of 10.0.0.2 !!!!!
Success rate is 100 percent (5/5), round-trip min/avg/max = 1/1/1 ms
R2#traceroute 1.1.1.1 source 10.0.0.2 Type escape sequence to abort. Tracing the route to
1.1.1.1
VRF info: (vrf in name/id, vrf out name/id) 1 10.0.0.1 2 msec 1 msec *
```

R2#ping 3.3.3.3 source 10.0.1.2 Type escape sequence to abort. Sending 5, 100-byte ICMP Echos to 3.3.3.3, timeout is 2 seconds:

Packet sent with a source address of 10.0.1.2 !!!!! Success rate is 100 percent (5/5), round-trip min/avg/max = 1/1/1 ms

R2#traceroute 3.3.3.3 source 10.0.1.2 Type escape sequence to abort. Tracing the route to 3.3.3.3 VRF info: (vrf in name/id, vrf out name/id) 1 10.0.1.3 0 msec 1 msec *

R3

Router>enable Router#conf t

Router(config)#hostname R

3 R3(config)#interface loopback 0

R3(config-if)#ip address 3.3.3.3 255.255.255.255

R3(config-if)#exit

R3(config)#int e0/0

R3(config-if)#ip address 10.0.1.3 255.255.255.0

R3(config-if)#no shu

t R3(config-if)#exit

R3(config)#router ospf 1

R3(config-router)#network 3.3.3.0 0.0.0.255 area 0

R3(config-router)#network 10.0.1.0 0.0.0.255 area 0

R3(config-router)#exit

R3#sh ip route osp

f Codes: L - local, C - connected, S - static, R - RIP, M - mobile, B - BGP D - EIGRP, EX - EIGRP external, O - OSPF, IA - OSPF inter area N1 - OSPF NSSA external type 1, N2 - OSPF NSSA external type 2 E1 - OSPF external type 1, E2 - OSPF external type 2 i - IS-IS, su - IS-IS summary,

L1 - IS-IS level-1, L2 - IS-IS level-2 ia - IS-IS inter area, * - candidate default, U - per-user static route o - ODR, P - periodic downloaded static route, H - NHRP, I - LISP a - application route + - replicated route, % - next hop override

Gateway of last resort is not set

1.0.0.0/32 is subnetted, 1 subnets O 1.1.1.1 [110/21] via 10.0.1.2, 00:03:45,

Ethernet0/0 2.2.2.2/32 is subnetted, 1 subnets O 2.2.2.2 [110/11] via 10.0.1.2, 00:03:45,

Ethernet0/0 10.0.0.0/8 is variably subnetted, 3 subnets, 2 masks O 10.0.0.0/24 [110/20] via 10.0.1.2, 00:03:45,

Ethernet0/0

R3#sh ip cef Prefix

Next Hop Interface 0.0.0.0/0 no route 0.0.0.0/8 drop 0.0.0.0/32 receive 1.1.1.1/32 10.0.1.2

Ethernet0/0 2.2.2.2/32 10.0.1.2 Ethernet0/0 3.3.3.3/32 receive Loopback0 10.0.0.0/24

10.0.1.2 Ethernet0/0 10.0.1.0/24 attached

Ethernet0/0 10.0.1.0/32 receive Ethernet0/0 10.0.1.2/32 attached Ethernet0/0 10.0.1.3/32

receive Ethernet0/0 10.0.1.255/32 receive

Ethernet0/0 127.0.0.0/8 drop 224.0.0.0/4 drop 224.0.0.0/24 receive 240.0.0.0/4 drop

255.255.255.255/32 receive

R3#sh ip route 1.1.1.1

Routing entry for 1.1.1.1/32 Known via "ospf 1", distance 110, metric 21, type intra area

Last update from 10.0.1.2 on Ethernet0/0, 00:23:51 ago Routing Descriptor Blocks: *

10.0.1.2, from 1.1.1.1, 00:23:51 ago, via Ethernet0/0 Route metric is 21, traffic share count

is 1

```

R3#sh ip route 2.2.2.2 Routing entry for 2.2.2.2/32 Known via "ospf 1", distance 110, metric
11, type intra area Last update from 10.0.1.2 on Ethernet0/0, 00:23:58 ago Routing
Descriptor Blocks: * 10.0.1.2, from 2.2.2.2, 00:23:58 ago, via Ethernet0/0 Route metric is 11,
traffic share count is 1
R3#sh ip cef 1.1.1.1 1.1.1.1/32 nexthop 10.0.1.2 Ethernet0/0
R3#sh ip cef 2.2.2.2 2.2.2.2/32 nexthop 10.0.1.2 Ethernet0/0
R3(config)#mpls label range 300 399
R3(config)#mpls lab
el protocol ldp
R3(config)#mpls ldp router-id loopback 0
R3(config)#int e0/0
R3(config-if)#mpls ip R3#sh mpls interfaces Interface IP Tunnel BGP Static Operational
Ethernet0/0 Yes (Ldp) No No No Yes R3#sh mpls ldp binding
lib entry: 1.1.1.1/32, rev 2 local binding: label: 300 remote
binding: lsr: 2.2.2.2:0, label: 200 lib entry: 2.2.2.2/32, rev 4 local
binding: label: 301 remote binding: lsr: 2.2.2.2:0, label: imp-null lib entry: 3.3.3.3/32,
rev 6 local binding: label: imp-null remote binding: lsr: 2.2.2.2:0, label: 201 lib entry:
10.0.0.0/24,
rev 8 local binding: label: 302 remote binding: lsr: 2.2.2.2:0, label: imp-null lib entry:
10.0.1.0/24,
rev 10 local binding: label: imp-null remote binding: lsr: 2.2.2.2:0, label: imp-null
R3#sh mpls ldp neighbor Peer LDP Ident: 2.2.2.2:0; Local LDP Ident 3.3.3.3:0
TCP connection: 2.2.2.2.646 - 3.3.3.3.44196 State: Oper; Msgs sent/rcvd: 51/51;
Downstream Up time: 00:38:15
LDP discovery sources:
Ethernet0/0, Src IP addr: 10.0.1.2 Addresses bound to peer LDP Ident: 10.0.0.2 10.0.1.2
2.2.2.2
R3#sh mpls forwarding-table
Local Outgoing Prefix Bytes
Label Outgoing Next Hop Label Label or Tunnel Id Switched interface 300 200 1.1.1.1/32 0
Et0/0 10.0.1.2 301 Pop Label 2.2.2.2/32 0 Et0/0 10.0.1.2 302 Pop Label 10.0.0.0/24 0 Et0/0
10.0.1.2
R3#sh ip cef 1.1.1.1 1.1.1.1/32 nexthop 10.0.1.2 Ethernet0/0 label 200
R3#sh ip cef 2.2.2.2 2.2.2.2/32 nexthop 10.0.1.2 Ethernet0/0
R3#ping 1.1.1.1 source 10.0.1.3 Type escape sequence to abort.
Sending 5, 100-byte ICMP Echos to 1.1.1.1, timeout is 2 seconds: Packet sent with a source
address of 10.0.1.3 !!!!!
Success rate is 100 percent (5/5), round-trip min/avg/max = 1/1/3 ms R3#traceroute 1.1.1.1
source 10.0.1.3
Type escape sequence to abort.
Tracing the route to 1.1.1.1
VRF info:
(vrf in name/id, vrf out name/id) 1 10.0.1.2 [MPLS: Label 200 Exp 0] 1 msec 2 msec 1 msec 2
10.0.0.1 2 msec 2 msec *
R3#ping 2.2.2.2 source 10.0.1.3 Type escape sequence to abort.
Sending 5, 100-byte ICMP Echos to 2.2.2.2, timeout is 2 seconds:

```

Packet sent with a source address of 10.0.1.3 !!!!!
Success rate is 100 percent (5/5), round-trip min/avg/max = 1/1/1 ms
R3#traceroute 2.2.2.2
source 10.0.1.3
Type escape sequence to abort. Tracing the route to 2.2.2.2
VRF info:
(vrf in name/id, vrf out name/id) 1 10.0.1.2 2 msec 2 msec *

Practical 9

NETWORK TOPOLOGY

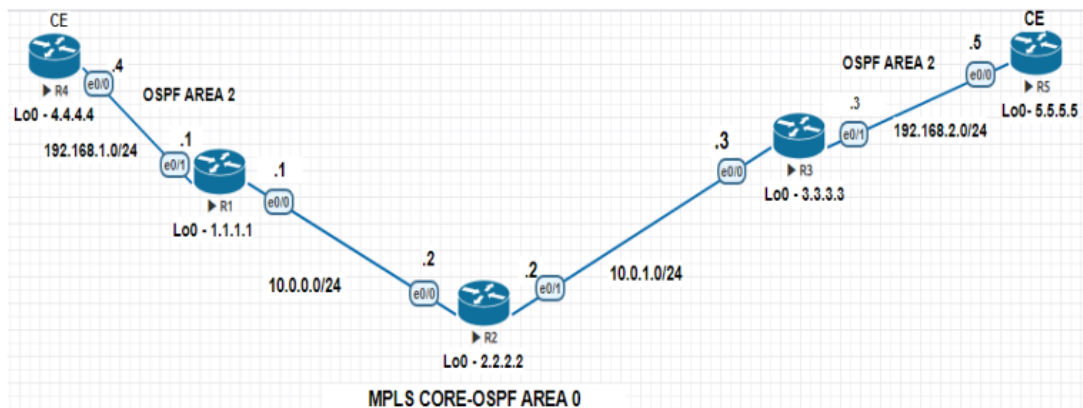

R1

```

Router>enable
Router#conf t
Router(config)#hostname R1
R1(config)# interface loopback 0
R1(config-if)#ip address 1.1.1.1 255.255.255.255
R1(config-if)#exit
R1(config)#int e0/0
R1(config-if)#ip address 10.0.0.1 255.255.255.0
R1(config-if)#no shut
R1(config)#int e0/1
R1(config-if)#ip address 192.168.1.1 255.255.255.0
R1(config-if)#no shut
R1(config)#router ospf 1
R1(config-router)#network 1.1.1.0 0.0.0.255 area 0
R1(config-router)#network 10.0.0.0 0.0.0.255 area 0
R1(config-router)#exit
R1(config)#mpls label range 100 199
R1(config)#mpls label protocol ldp
R1(config)#mpls ldp router-id loopback 0
R1(config)#int e0/0
R1(config-if)#mpls ip
R1(config)#ip vrf A-1
R1(config-vrf)#rd 500:1
R1(config-vrf)#route-target import 500:1
R1(config-vrf)#route-target export 500:1
R1(config-vrf)#exit
R1(config)#exit
R1#sh ip vrf Name Default RD Interfaces A-1 500:1
R1#sh ip vrf detail VRF A-1 (VRF Id = 1);
default RD 500:1;
default VPNID Old CLI format, supports IPv4 only
Flags: 0xC No interfaces Address family
ipv4 unicast (Table ID = 0x1):
Flags: 0x0 Export VPN route-target communities
RT:500:1
Import VPN route-target communities
RT:500:1
No import route-map
No global export route-map
No export route-map
VRF label distribution protocol: not configured
VRF label allocation mode: per-prefix
R1(config)#int e0/1
  
```

```

R1(config-if)#ip vrf forwarding A-1 % Interface Ethernet0/1 IPv4 disabled and address(es)
removed due to enabling VRF A-1 R1(config-if)#ip address 192.168.1.1 255.255.255.0
R1(config-if)#end
R1#sh ip route vrf A-1
Routing Table: A-1 Codes: L - local, C - connected, S - static, R - RIP, M - mobile, B - BGP D -
EIGRP, EX - EIGRP external, O - OSPF, IA - OSPF inter area N1 - OSPF NSSA external type 1, N2
- OSPF NSSA external type 2 E1 - OSPF external type 1, E2 - OSPF external type 2 i - IS-IS, su -
IS-IS
summary,
L1 - IS-IS level-1, L2 - IS-IS level-2 ia - IS-IS inter area, * - candidate default, U - per-user static
route o - ODR, P - periodic downloaded static route, H - NHRP, I - LISP a - application route +
- replicated route, % - next hop override
Gateway of last resort is not set
192.168.1.0/24 is variably subnetted, 2 subnets, 2 masks
C 192.168.1.0/24 is directly connected, Ethernet0/1
L 192.168.1.1/32 is directly connected, Ethernet0/1
R1#sh ip vrf Name Default RD Interfaces A-1 500:1 Et0/1
R1(config)#router ospf 10 vrf A-1
R1(config-router)#network 192.168.1.0 0.0.0.255 area 10
R1(config-router)#end
R1#sh ip ospf neighbor Neighbor ID Pri State Dead Time Address In
terface 2.2.2.2 1 FULL/DR 00:00:39 10.0.0.2 Ethernet0/0 4.4.4.4 1 FULL/DR 00:00:38
192.168.1.4 Ethernet0/1 R1#sh ip ospf 10 neighbor Neighbor ID Pri State Dead Time Address
Interface 4.4.4.4 1 FULL/DR 00:00:38 192.168.1.4 Ethernet0/1
R1#sh ip route vrf A-1 ospf
Routing Table: A-1 Codes: L - local, C - connected, S - static, R - RIP, M - mobile, B - BGP D -
EIGRP, EX - EIGRP external, O - OSPF, IA - OSPF inter area N1 - OSPF NSSA external type 1, N2
- OSPF NSSA external type 2 E1 - OSPF external type 1, E2 - OSPF external type 2 i - IS-IS, su -
IS-IS
summary,
L1 - IS-IS level-1,
L2 - IS-IS level-2 ia - IS-IS inter area,
* - candidate default,
U - per-user static route o - ODR
, P - periodic downloaded static route, H - NHRP,
I - LISP a - application route + - replicated route,
% - next hop override Gateway of last resort is not set 4.0.0.0/32 is subnetted, 1 subnets O
4.4.4.4 [110/11] via 192.168.1.4, 00:03:58, Ethernet0/1 R1(config)#router bgp 500
R1(config-router)#no bgp default ipv4-unicast
R1(config-router)#neighbor 3.3.3.3 remote-as 500
R1(config-router)#neighbor 3.3.3.3 update-source loopback 0
R1(config-router)#address-family vpnv4 unicast
R1(config-router-af)#neighbor 3.3.3.3 activate R1(config-router-af)#neighbor 3.3.3.3 send-
community extended R1(config-router-af)#neighbor 3.3.3.3 next-hop-self R1(config-router-
af)#end
R1#sh ip bgp vpnv4 all summary

```

```

BGP router identifier 1.1.1.1, local AS number 500 BGP table version is 1, main routing table
version 1 Neighbor V AS MsgRcvd MsgSent TblVer InQ OutQ Up/Down State/PfxRcd 3.3.3.3
4 500 6 7 1 0 0 00:03:19 0
R1(config)#router bgp 500
R1(config-router)#address-family ipv4 vrf A-1
R1(config-router-af)#redistribute ospf 10 vrf A-1 match internal external 1 external 2
R1(config-router-af)#exit R1(config-router)#exit
R1(config)#router ospf 10 vrf A-1
R1(config-router)#redistribute bgp 500 subnets
R1(config-router)#end R1#sh ip bgp vpnv4 all BGP table version is 7, local router ID is 1.1.1.1
Status codes: s suppressed, d damped, h history, * valid, > best, i - internal, r RIB-failure, S
Stale, m multipath, b backup-path, f RT-Filter, x best-external, a additional-path, c RIB-
compressed, Origin codes: i - IGP, e - EGP, ? - incomplete RPKI validation codes: V valid, I
invalid, N Not found
Network      Next Hop  Metric  LocPrf Weight Path Route Distinguisher: 500:1 (default for
vrf A-1)
*> 4.4.4.4/32 192.168.1.4 11          32768 ?
*>i 5.5.5.5/32 3.3.3.3 11    100          0 ?
*> 192.168.1. 0 0.0.0.0    0          32768 ?
*>i 192.168.2.0 3.3.3.3    0          100 0 ?
R1#sh ip route vrf A-1
Routing Table: A-1 Codes: L - local, C - connected, S - static, R - RIP, M - mobile, B - BGP D -
EIGRP, EX - EIGRP external, O - OSPF, IA - OSPF inter area N1 - OSPF NSSA external type 1, N2
- OSPF NSSA external type 2 E1 - OSPF external type 1, E2 - OSPF external type 2 i - IS-IS, su
- IS-IS
summary,
L1 - IS-IS level-1, L2 - IS-IS level-2 ia - IS-IS inter area, * - candidate default, U - per-user static
route o - ODR, P - periodic downloaded static route, H - NHRP, I - LISP a - application route +
- replicated route, % - next hop override
Gateway of last resort is not set
4.0.0.0/32 is subnetted, 1 subnets O 4.4.4.4 [110/11] via 192.168.1.4, 07:36:09, Ethernet0/1
5.0.0.0/32 is subnetted, 1 subnets B 5.5.5.5 [200/11] via 3.3.3.3, 00:06:15 192.168.1.0/24 is
variably subnetted, 2 subnets, 2 masks
C 192.168.1.0/24 is directly connected, Ethernet0/1 L 192.168.1.1/32 is directly connected,
Ethernet0/1 B 192.168.2.0/24 [200/0] via 3.3.3.3, 00:06:15
R1#sh ip route vrf A-1 bgp
Routing Table: A-1 Codes: L - local, C - connected, S - static, R - RIP, M - mobile, B - BGP D -
EIGRP, EX - EIGRP external, O - OSPF, IA - OSPF inter area N1 - OSPF NSSA external type 1, N2
- OSPF NSSA external type 2 E1 - OSPF external type 1, E2 - OSPF external type 2 i - IS-IS, su
- IS-IS summary, L1 - IS-IS level-1, L2 - IS-IS level-2 ia - IS-IS inter area, * - candidate default, U -
per-user static route o - ODR, P - periodic downloaded static route, H - NHRP, I - LISP a -
application route + - replicated route, % - next hop override
Gateway of last resort is not set 5.0.0.0/32 is subnetted, 1 subnets B 5.5.5.5 [200/11] via
3.3.3.3, 00:07:31 B 192.168.2.0/24 [200/0] via 3.3.3.3, 00:07:31
R1#ping vrf A-1 4.4.4.4
Type escape sequence to abort.
Sending 5, 100-byte ICMP Echos to 4.4.4.4, timeout is 2 seconds: !!!!!

```

Success rate is 100 percent (5/5), round-trip min/avg/max = 1/2/6 ms

R2

```
Router>enable
```

```
Router#conf t
```

```
Router(config)#hostname R2
```

```
R2(config)# interface loopback 0
```

```
R2(config-if)#ip address 2.2.2.2 255.255.255.255
```

```
R2(config-if)# exit
```

```
R2(config)#int e0/0
```

```
R2(config-if)#ip address 10.0.0.2 255.255.255.0
```

```
R2(config-if)#no shut
```

```
R2(config)#int e0/1
```

```
R2(config-if)#ip address 10.0.1.2 255.255.255.0
```

```
R2(config-if)#no shut
```

```
R2(config)#router ospf 1
```

```
R2(config-router)#network 2.2.2.0 0.0.0.255 area 0
```

```
R2(config-router)#network 10.0.0.0 0.0.0.255 area 0
```

```
R2(config-router)#network 10.0.1.0 0.0.0.255 area 0
```

```
R2(config-router)#exit
```

```
R2(config)#mpls label range 200 299 R2(config)#mpls label protocol ldp
```

```
R2(config)#mpls ldp router-id loopback 0
```

```
R2(config)#int e0/0 R2(config-if)#mpls ip
```

```
R2(config-if)#int e0/1
```

```
R2(config-if)#mpls ip
```

R3

```
Router>enable
```

```
Router#conf t
```

```
Router(config)#hostname
```

R3

```
R3(config)#interface loopback 0
```

```
R3(config-if)#ip address 3.3.3.3 255.255.255.255
```

```
R3(config-if)#exit
```

```
R3(config)#int e0/0
```

```
R3(config-if)#ip address 10.0.1.3 255.255.255.0
```

```
R3(config-if)#no shut
```

```
R3(config-if)#exit
```

```
R3(config)#interface e0/1
```

```
R3(config-if)#ip address 192.168.2.3 255.255.255.0
```

```
R3(config-if)#no shut
```

```
R3(config-if)#exit
```

```
R3(config)#router ospf 1
```

```
R3(config-router)#network 3.3.3.0 0.0.0.255 area 0
```

```
R3(config-router)#network 10.0.1.0 0.0.0.255 area 0
```

```
R3(config-router)#exit
```

```
R3(config)#mpls label range 300 399
```

```
R3(config)#mpls label protocol ldp
```

```
R3(config)#mpls ldp router-id loopback 0
```

```

R3(config)#int e0/0
R3(config-if)#mpls ip
R3(config)#ip vrf A-2
R3(config-vrf)#rd 500:1
R3(config-vrf)#route-target import 500:1
R3(config-vrf)#route-target export 500:1
R3#sh ip vrf Name Default RD Interfaces A-2 500:1
R3#sh ip vrf detail
VRF A-2 (VRF Id = 1);
default RD 500:1; default VPNID Old CLI format, supports IPv4 only Flags: 0xC No interfaces
Address family ipv4 unicast (Table ID = 0x1): Flags: 0x0 Export VPN route-target
communities RT:500:1 Import VPN route-target communities RT:500:1 No import route-map
No global export route-map No export route-map VRF label distribution protocol: not
configured VRF label allocation mode: per-prefix R3(config)#int e0/1 R3(config-if)#ip vrf
forwarding A-2 % Interface Ethernet0/1 IPv4 disabled and address(es) removed due to
enabling VRF A-2 R3(config-if)#ip address 192.168.2.3 255.255.255.0
R3(config-if)#end
R3#sh ip route vrf A-2 Routing Table: A-2
Codes: L - local, C - connected, S - static, R - RIP, M - mobile, B - BGP D - EIGRP, EX - EIGRP
external, O - OSPF, IA - OSPF inter area N1 - OSPF NSSA external type 1, N2 - OSPF NSSA
external type 2 E1 - OSPF external type 1, E2 - OSPF external type 2 i - IS-IS, su - IS-IS
summary, L1 - IS-IS level-1, L2 - IS-IS level-2 ia - IS-IS inter area, * - candidate default, U - per-
user static route o - ODR, P - periodic downloaded static route, H - NHRP, I - LISP a -
application route + - replicated route, % - next hop override
Gateway of last resort is not set
192.168.2.0/24 is variably subnetted, 2 subnets, 2 masks C 192.168.2.0/24 is directly
connected,
Ethernet0/1 L 192.168.2.3/32 is directly connected,
Ethernet0/1
R3#sh ip vrf Name Default RD Interfaces A-2 500:1 Et0/1
R3(config)#router ospf 10 vrf A-2
R3(config-router)#network 192.168.2.0 0.0.0.255 area 0 R3(config-router)#end R3#sh ip
ospf 10 neighbor Neighbor ID Pri State Dead Time Address Interface 5.5.5.5 1 FULL/DR
00:00:33 192.168.2.5 Ethernet0/1
R3#sh ip route vrf A-2 ospf
Routing Table: A-2
Codes: L - local, C - connected, S - static, R - RIP, M - mobile, B - BGP D - EIGRP, EX - EIGRP
external, O - OSPF, IA - OSPF inter area N1 - OSPF NSSA external type 1, N2 - OSPF NSSA
external type 2 E1 - OSPF external type 1, E2 - OSPF external type 2 i - IS-IS, su - IS-IS
summary, L1 - IS-IS level-1, L2 - IS-IS level-2 ia - IS-IS inter area, * - candidate default, U - per-
user static route o - ODR, P - periodic downloaded static route, H - NHRP, I - LISP a -
application route + - replicated route, % - next hop override
Gateway of last resort is not set
5.0.0.0/32 is subnetted, 1 subnets O 5.5.5.5 [110/11] via 192.168.2.5, 00:06:37,
Ethernet0/1
R3(config)#router bgp 500

```

```

R3(config-router)#no bgp default ipv4-unicast R3(config-router)#neighbor 1.1.1.1 remote-as
500
R3(config-router)#neighbor 1.1.1.1 update-source loopback 0 R3(config-router)#address-
family vpnv4 unicast
R3(config-router-af)#neighbor 1.1.1.1 activate
R3(config-router-af)#neighbor 1.1.1.1 send-community extended
R3(config-router-af)#neighbor 1.1.1.1 next-hop-self
R3#sh ip bgp vpnv4 all
summary
BGP router identifier 3.3.3.3, local AS number 500 BGP table version is 1, main routing table
version 1 Neighbor V AS MsgRcvd MsgSent TblVer InQ OutQ Up/Down State/PfxRcd 1.1.1.1
4 500 7 6 1 0 0 00:03:01
R3(config)#router bgp 500
R3(config-router)#address-family ipv4 vrf A-2
R3(config-router-af)#redistribute ospf 10 vrf A-2 match internal external 1 external 2
R3(config-router-af)#exit R
3(config-router)#exit
R3(config)#router ospf 10 vrf A-2
R3(config-router)#redistribute bgp 500 subnets
R3(config-router)#end
R3#sh ip bgp vpnv4 all
BGP table version is 7, local router ID is 3.3.3.3
Status codes: s suppressed, d damped, h history, * valid, > best, i - internal, r RIB-failure, S
Stale, m multipath, b backup-path, f RT-Filter, x best-external, a additional-path, c RIB-
compressed, Origin codes: i - IGP, e - EGP, ? - incomplete RPKI validation codes: V valid, I
invalid, N Not found
Network      Next Hop    Metric    LocPrf Weight Path Route Distinguisher: 500:1 (default
for vrf A-2)
*>i 4.4.4.4/32  1.1.1.1      11                100 0 ?
*> 5.5.5.5/32  192.168.2.5  11                32768 ?
*>i 192.168.1.0 1.1.1.1      0                 100 0 ?
*> 192.168.2.0  0.0.0.0      0                 32768 ?
R3#sh ip route vrf A-2
Routing Table: A-2
Codes: L - local, C - connected, S - static, R - RIP, M - mobile, B - BGP D - EIGRP, EX - EIGRP
external, O - OSPF, IA - OSPF inter area N1 - OSPF NSSA external type 1, N2 - OSPF NSSA
external type 2 E1 - OSPF external type 1, E2 - OSPF external type 2 i - IS-IS, su - IS-IS
summary, L1 - IS-IS level-1, L2 - IS-IS level-2 ia - IS-IS inter area, * - candidate default, U - per-
user static route o - ODR, P - periodic downloaded static route, H - NHRP, I - LISP a -
application route + - replicated route, % - next hop override
Gateway of last resort is not set
4.0.0.0/32 is subnetted, 1 subnets B 4.4.4.4 [200/11] via 1.1.1.1, 00:55:23 5.0.0.0/32 is
subnetted, 1 subnets O 5.5.5.5 [110/11] via 192.168.2.5, 01:50:21,
Ethernet0/1 B 192.168.1.0/24 [200/0] via 1.1.1.1, 00:55:23 192.168.2.0/24 is variably
subnetted, 2 subnets, 2 masks C 192.168.2.0/24 is directly connected,
Ethernet0/1 L 192.168.2.3/32 is directly connected, Ethernet0/1 R3#ping vrf A-2 5.5.5.5 T
ype escape sequence to abort.

```

```

Sending 5, 100-byte ICMP Echos to 5.5.5.5, timeout is 2 seconds: !!!!!
Success rate is 100 percent (5/5), round-trip min/avg/max = 1/1/1 ms
R4 Router>enable
Router#conf t
Router(config)#hostname R4
R4(config)#int loopback 0
R4(config-if)#ip address 4.4.4.4 255.255.255.255
R4(config-if)#exit
R4(config)#int e0/0
R4(config-if)#ip address 192.168.1.4 255.255.255.0
R4(config-if)#no shutdown
R4(config-if)#exit
R4(config)#router ospf 1
R4(config-router)#network 4.4.4.0 0.0.0.255 area 10
R4(config-router)#network 192.168.1.0 0.0.0.255 area 10
R4(config-router)#exit
R4#sh ip route ospf
Codes: L - local, C - connected, S - static, R - RIP, M - mobile, B - BGP D - EIGRP, EX - EIGRP
external, O - OSPF, IA - OSPF inter area N1 - OSPF NSSA external type 1, N2 - OSPF NSSA
external type 2 E1 - OSPF external type 1, E2 - OSPF external type 2 i - IS-IS, su - IS-IS
summary, L1 - IS-IS level-1, L2 - IS-IS level-2 ia - IS-IS inter area, * - candidate default, U - per-
user static route o - ODR, P - periodic downloaded static route, H - NHRP, I - LISP a -
application route + - replicated route, % - next hop override
Gateway of last resort is not set
5.0.0.0/32 is subnetted, 1 subnets O IA 5.5.5.5 [110/21] via 192.168.1.1, 00:23:41,
Ethernet0/0 O IA 192.168.2.0/24 [110/11] via 192.168.1.1, 00:23:41,
Ethernet0/0 R4#ping 5.5.5.5 source lo 0
Type escape sequence to abort.
Sending 5, 100-byte ICMP Echos to 5.5.5.5, timeout is 2 seconds:
Packet sent with a source address of 4.4.4.4 !!!!!
Success rate is 100 percent (5/5), round-trip min/avg/max = 1/1/2 ms R5
Router>enable
Router#conf t
Router(config)#hostname R5
R5(config)#int loopback 0
R5(config-if)#ip address 5.5.5.5 255.255.255.255
R5(config-if)#exit
R5(config)#int e0/0
R5(config-if)#ip address 192.168.2.5 255.255.255.
R5(config-if)#no shutdown
R5(config-if)#exit
R5(config)#router ospf 1
R5(config-router)#network 5.5.5.0 0.0.0.255 area 0
R5(config-router)#network 192.168.2.0 0.0.0.255 area 0 R5(config-router)#exit
R5#sh ip route ospf Codes: L - local, C - connected, S - static, R - RIP, M - mobile, B - BGP D -
EIGRP, EX - EIGRP external, O - OSPF, IA - OSPF inter area N1 - OSPF NSSA external type 1, N2

```

- OSPF NSSA external type 2 E1 - OSPF external type 1, E2 - OSPF external type 2 i - IS-IS, su - IS-IS

summary, L1 - IS-IS level-1, L2 - IS-IS level-2 ia - IS-IS inter area, * - candidate default, U - per-user static route o - ODR, P - periodic downloaded static route, H - NHRP, I - LISP a - application route + - replicated route, % - next hop override

Gateway of last resort is not set 4.0.0.0/32 is subnetted, 1 subnets O IA 4.4.4.4 [110/21] via 192.168.2.3, 00:23:51, Ethernet0/0 O IA 192.168.1.0/24 [110/11] via 192.168.2.3, 00:23:51, Ethernet0/0

R5#ping 4.4.4.4 source lo 0

Type escape sequence to abort. Sending 5, 100-byte ICMP Echos to 4.4.4.4, timeout is 2 seconds: Packet sent with a source address of 5.5.5.5 !!!!!

Success rate is 100 percent (5/5), round-trip min/avg/max = 2/2/3 ms